

DOMO FACHADA

SISTEMA FACHADA

INDALS

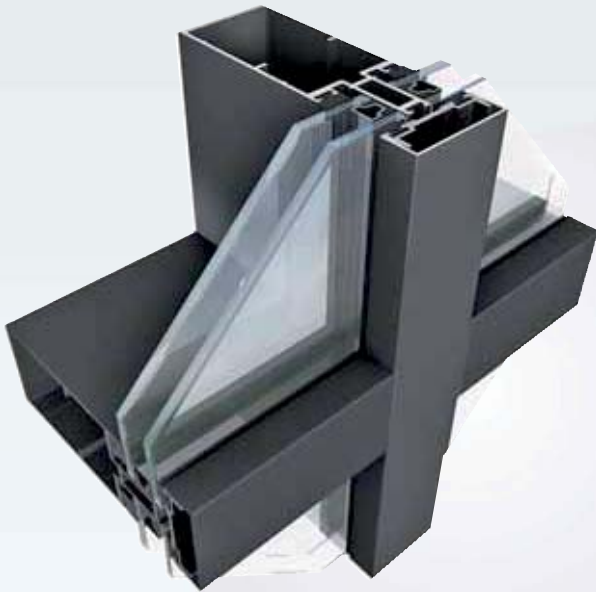

CARACTERÍSTICAS

- Estructura portante a base de perfiles verticales (montantes) y horizontales (travesaños).
- Posibilidad de sistema de perfil visto, semiestructural y estructural.
- Sección interior vista de 50 mm y 56 mm, tanto en montantes como en travesaños.
- Juntas de estanquidad en E.P.D.M.
- Sistema rápido de fijación montante - travesaño.

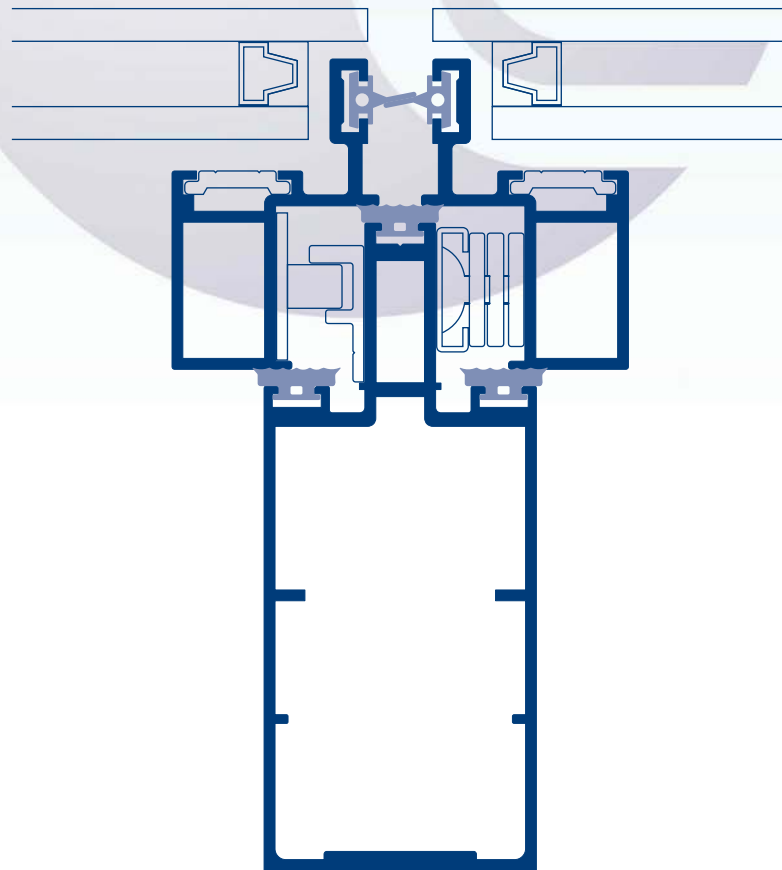

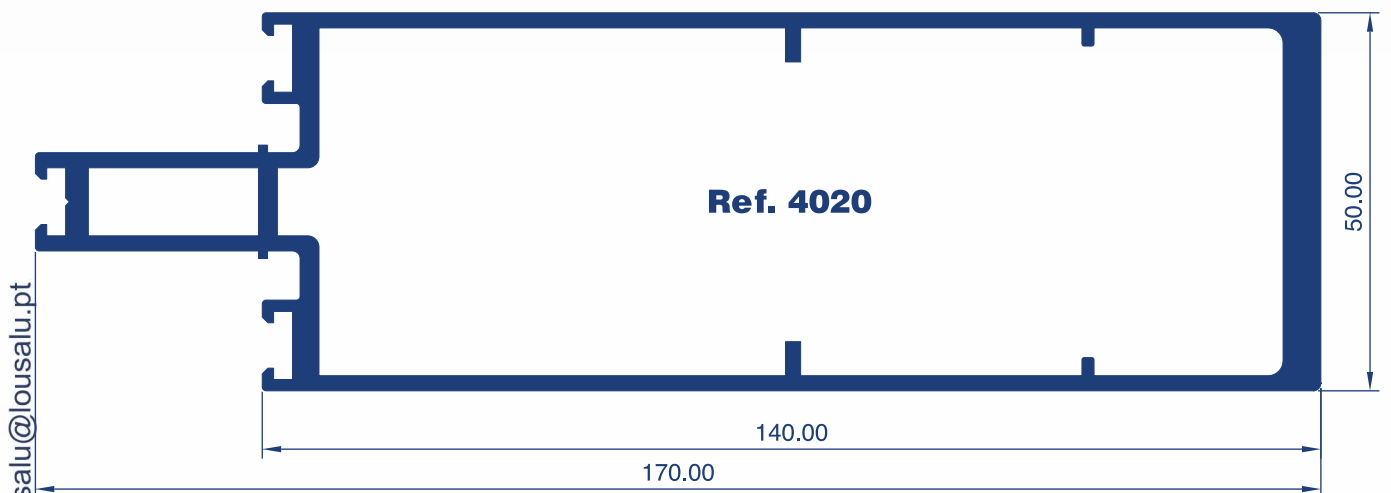
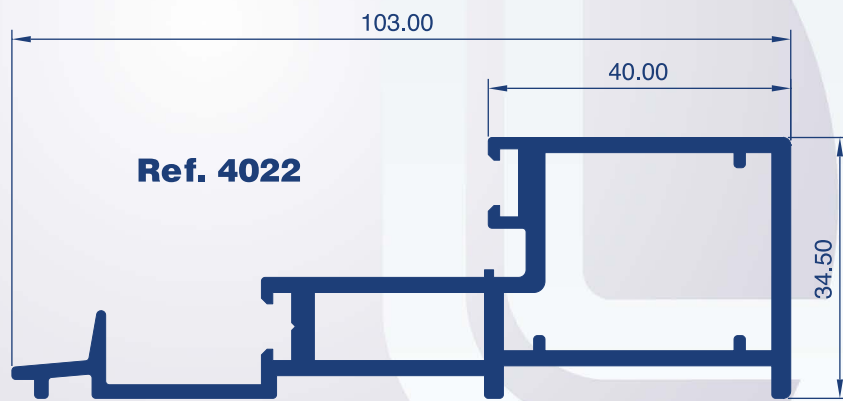
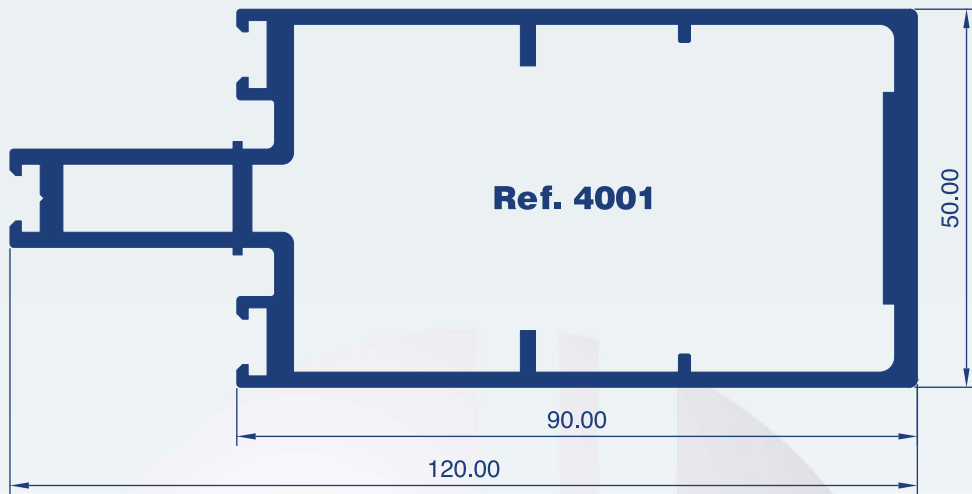

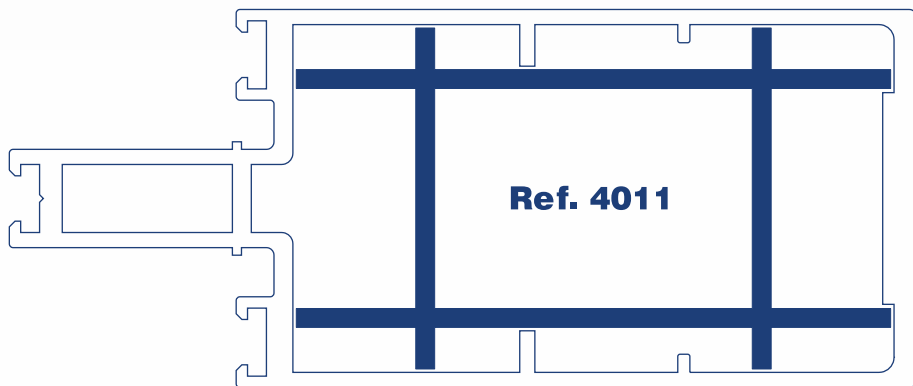
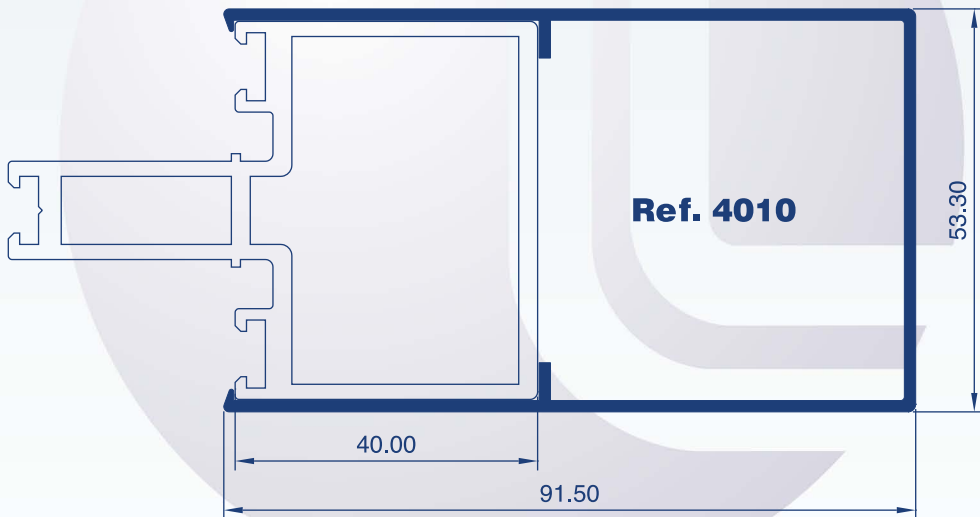
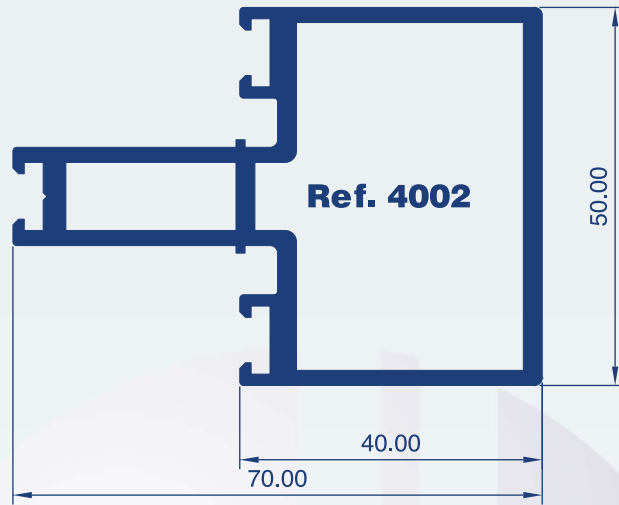

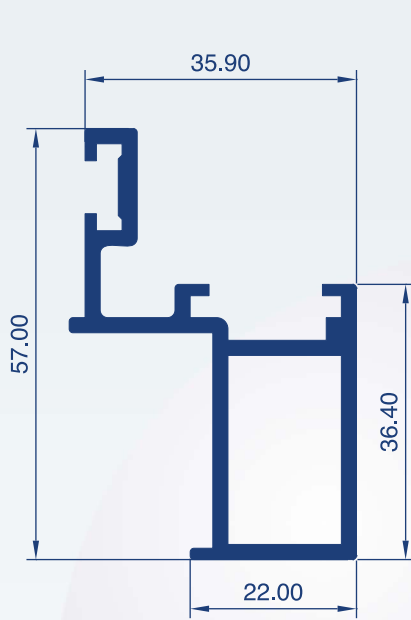

Ref. 4007

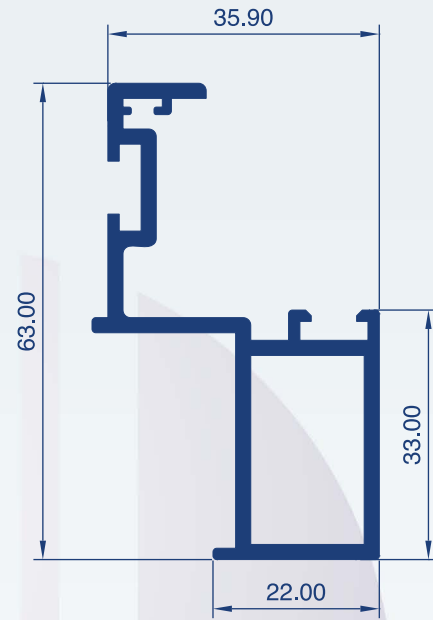

Ref. 4023

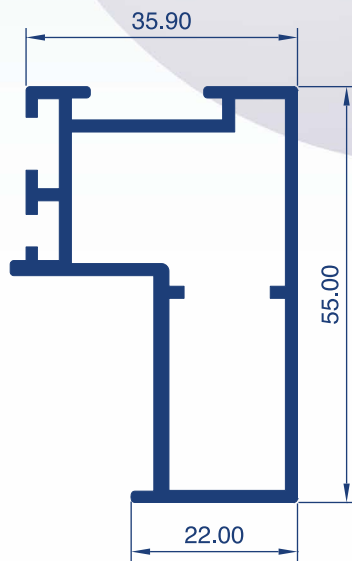

Ref. 4024

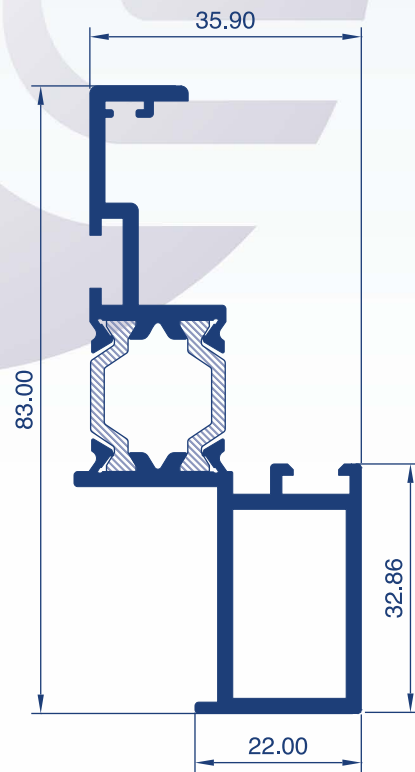

Ref. 4027

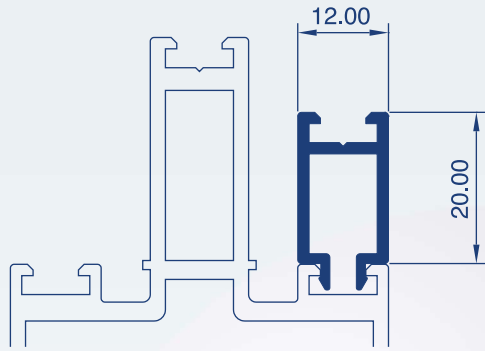

Ref. 4021

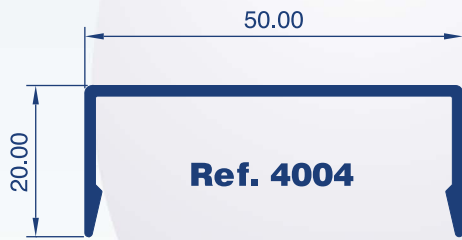

Ref. 4004

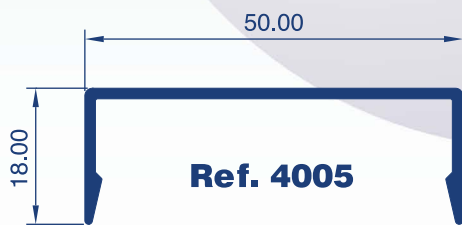

Ref. 4005





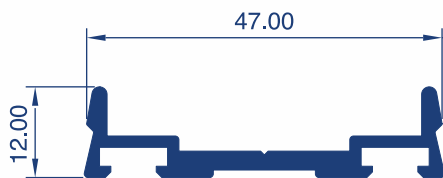

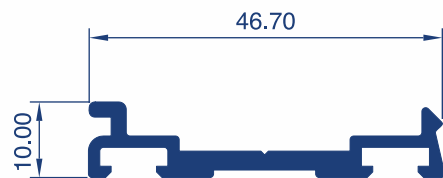

Ref. 4030

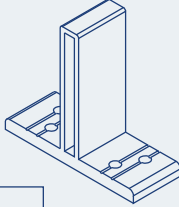

Ref. 4003

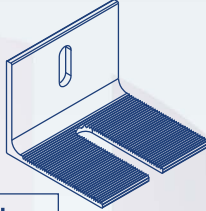

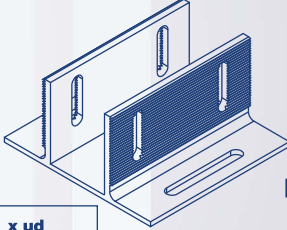
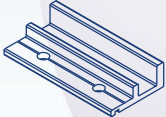
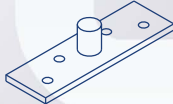
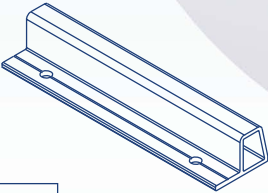
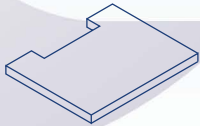
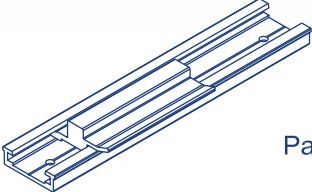
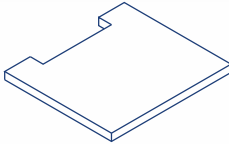
Ref. 4029

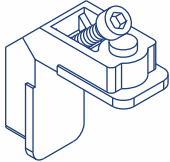
 <p>Ref. 31112 Junta travesaño</p> <p>200ml / caja</p>	 <p>Ref. 30940 Tope travesaño</p> <p>x ud</p>
 <p>Ref. 31113 Junta montante</p> <p>100ml / caja</p>	 <p>Ref. 30503 Ángulo anclaje forjado</p> <p>x ud</p>
 <p>Ref. 31070 Junta exterior fachada estructural y semiestructural</p> <p>200ml / caja</p>	 <p>Ref. 30945 Omega anclaje forjado para montante de 50mm</p> <p>x ud</p>
 <p>Ref. 30941 Anclaje lateral hoja</p> <p>x ud</p>	 <p>Ref. 30780 Anclaje hoja fachada</p> <p>x ud</p>
 <p>Ref. 30942 Anclaje inferior hoja</p> <p>x ud</p>	 <p>Ref. 30276 Junta estanqueidad travesaño 50mm</p> <p>x ud</p>
 <p>Ref. 30943 Pasador hoja fachada</p> <p>x ud</p>	 <p>Ref. 30277 Junta estanqueidad travesaño 56mm</p> <p>x ud</p>
 <p>Ref. 30195 Escuadra alineación 30x9x2.4mm</p> <p>250uds / bolsa</p>	 <p>Ref. 30180 Escuadra de tetón 24x14</p> <p>250uds / caja</p>

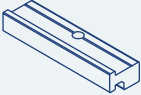
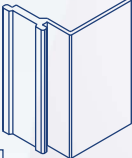
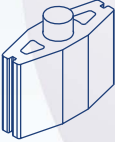
 <p>x ud</p>	<p>Ref. 30502</p> <p>Pletina complemento anclaje</p>	
 <p>x ud</p>	<p>Ref. 30946</p> <p>Anclaje exterior hoja estructural</p>	
 <p>x ud</p>	<p>Ref. 30947</p> <p>Soporte vidrio hoja estructural</p>	
 <p>x ud</p>	<p>Ref. 30944</p> <p>Antigiro</p>	

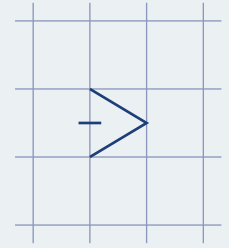

Ref. 31112

Ref. 31113

Ref. escuadra 30195

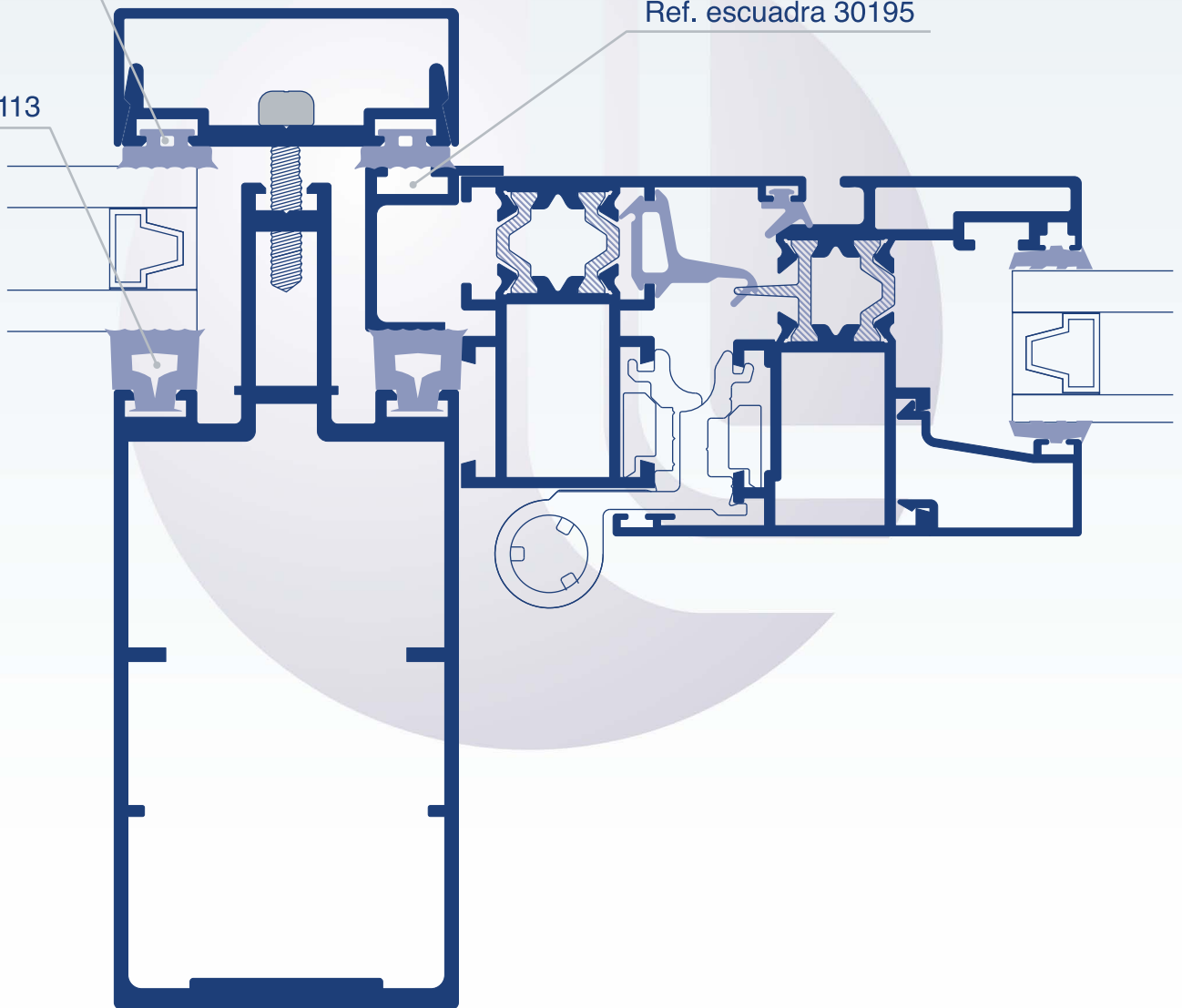

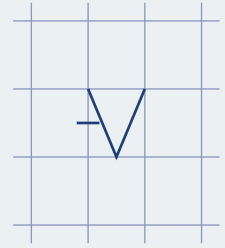

Ref. 31112

Ref. 31113

Ref. escuadra 30195

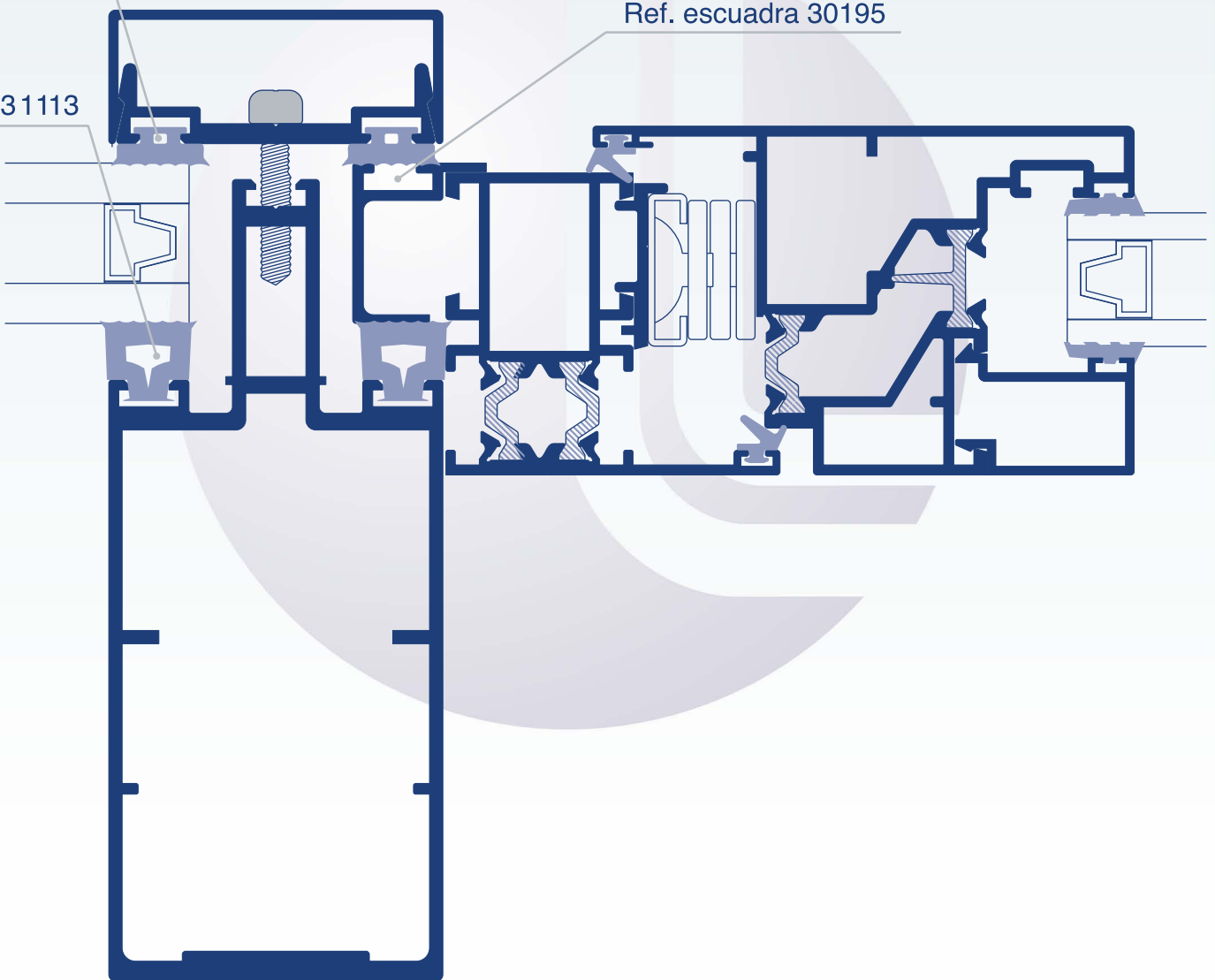

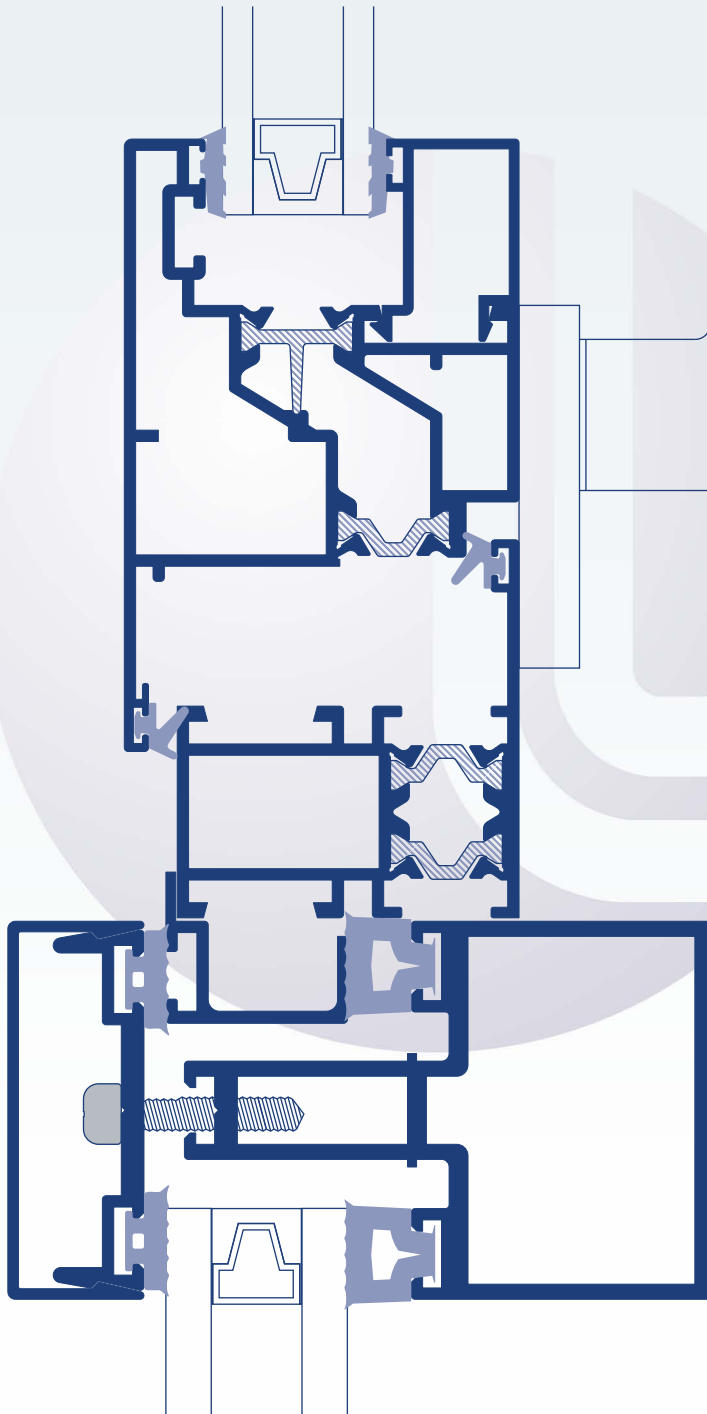
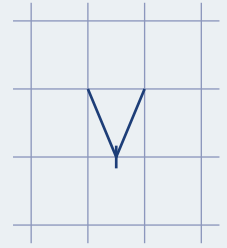

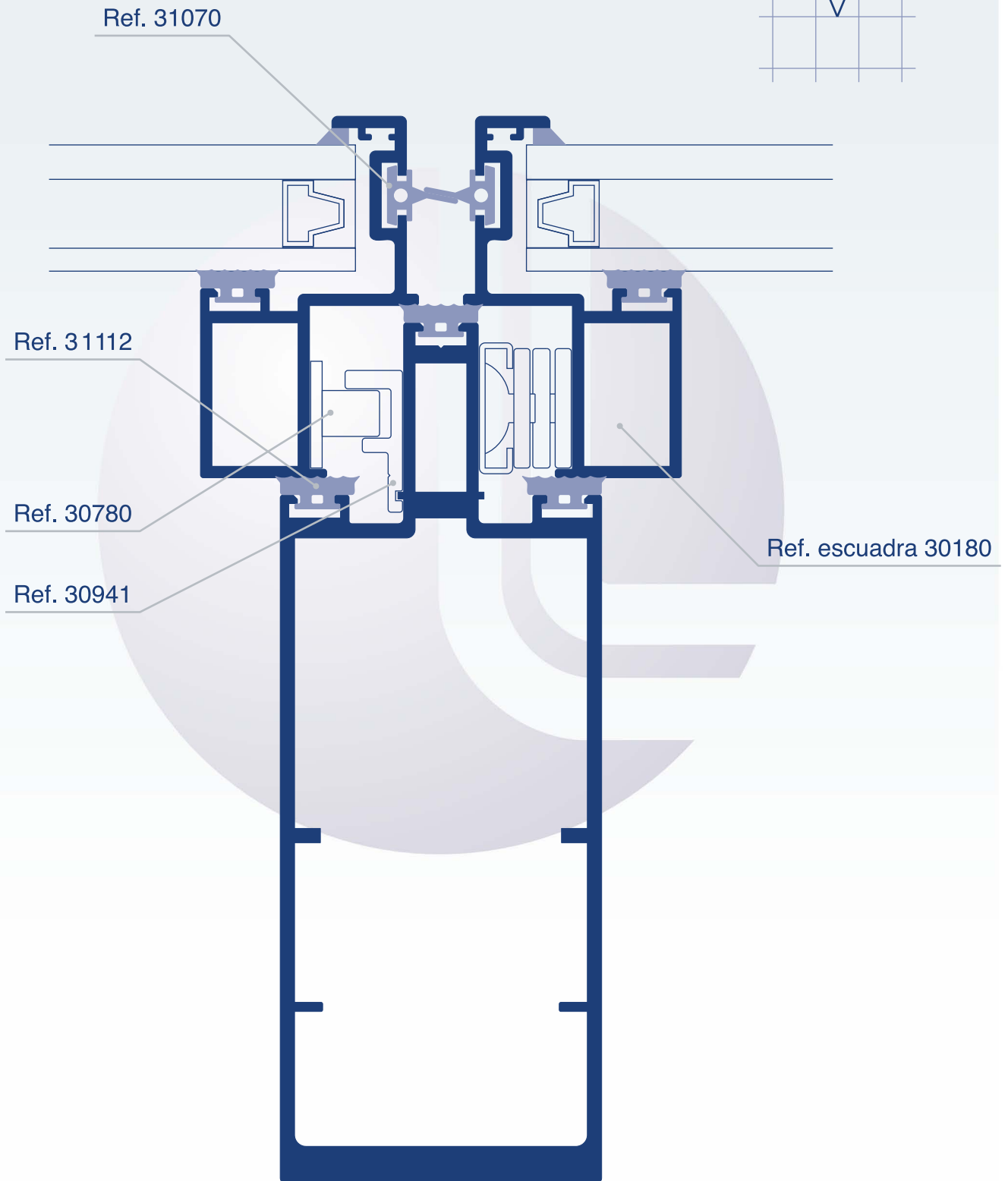
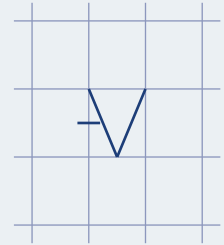

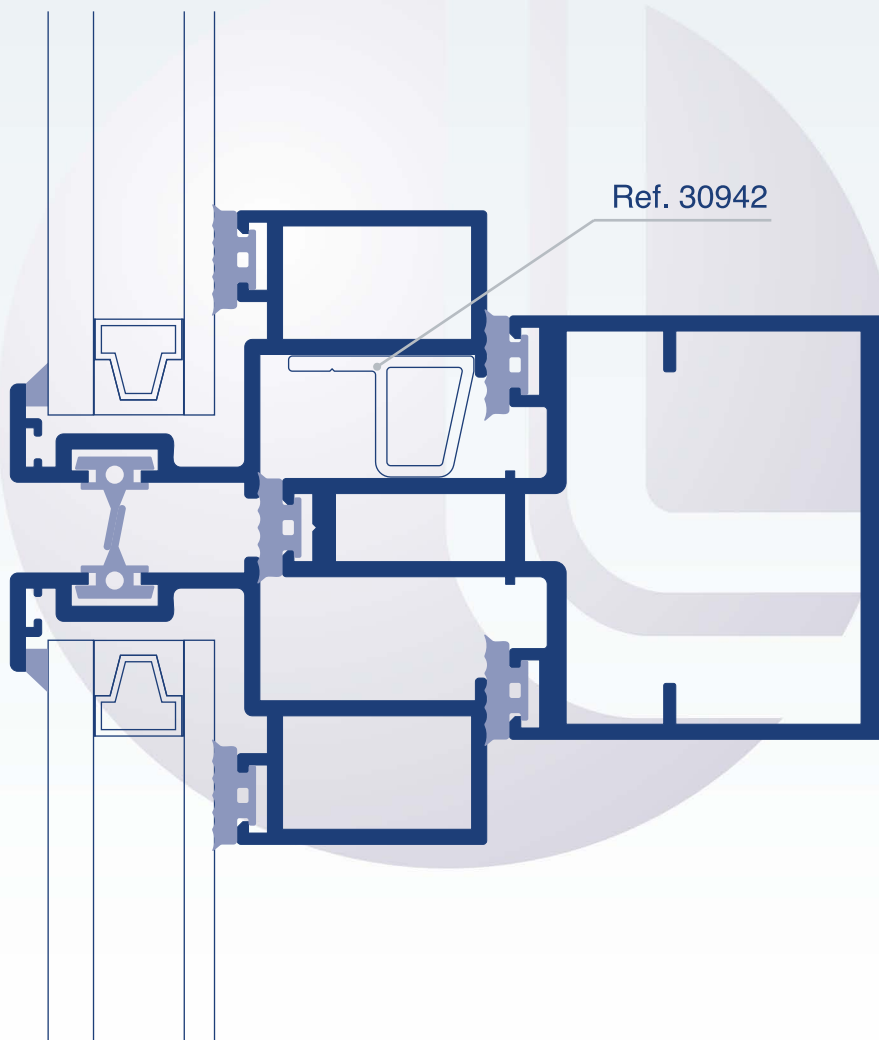
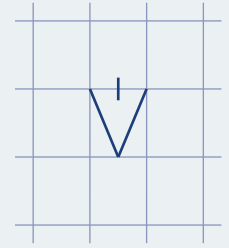

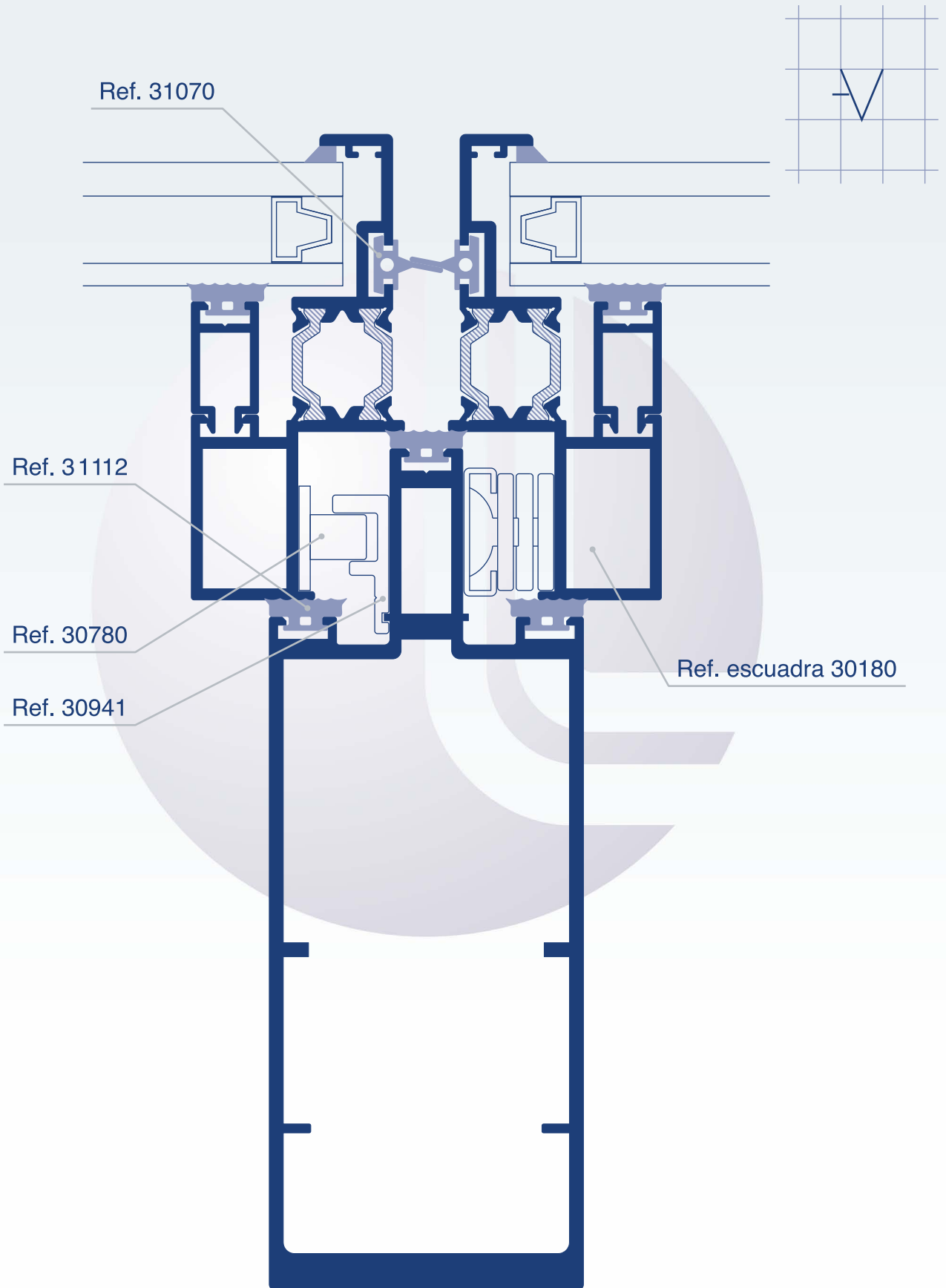

FACHADA SEMIESTRUCTURAL - HOJA ROTURA TÉRMICA
Sección Horizontal

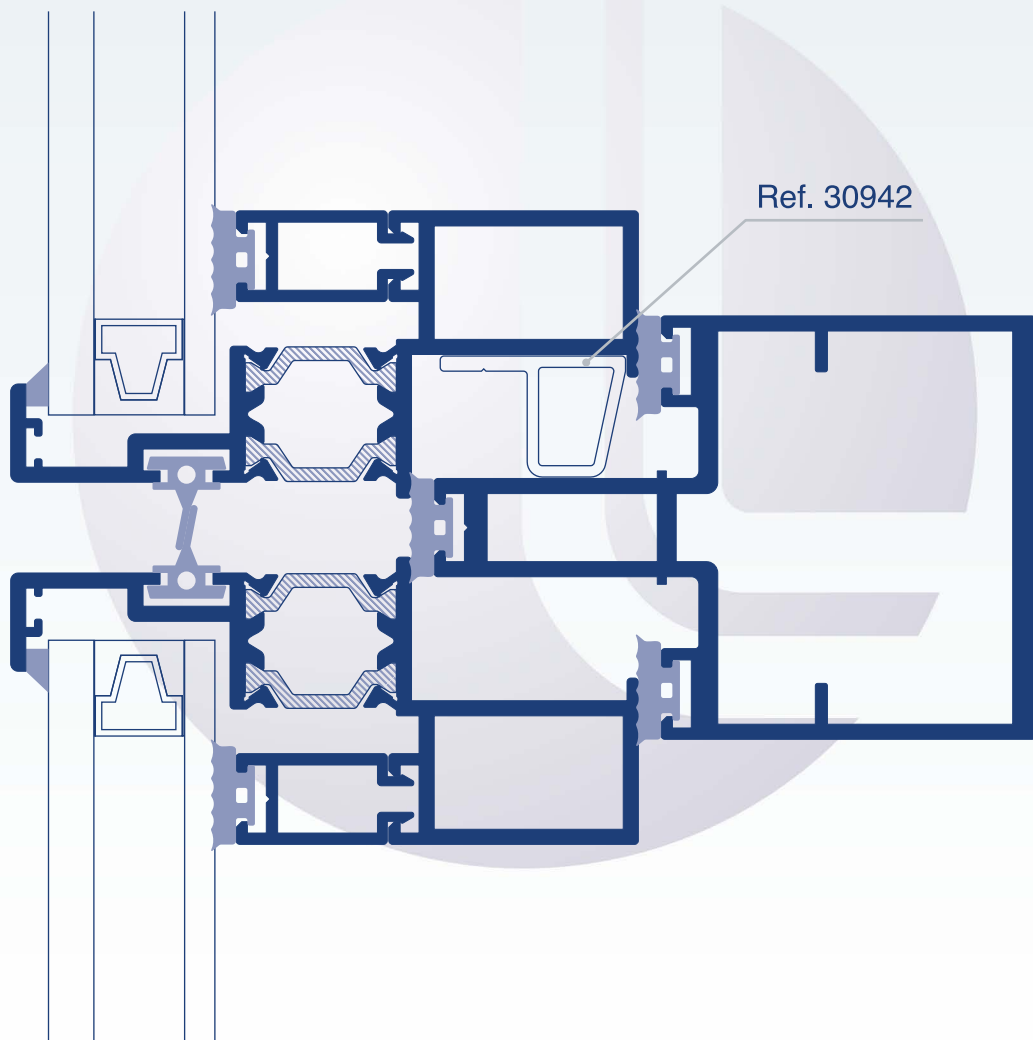
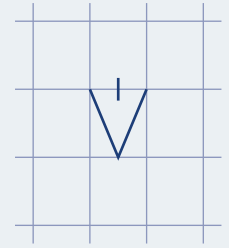

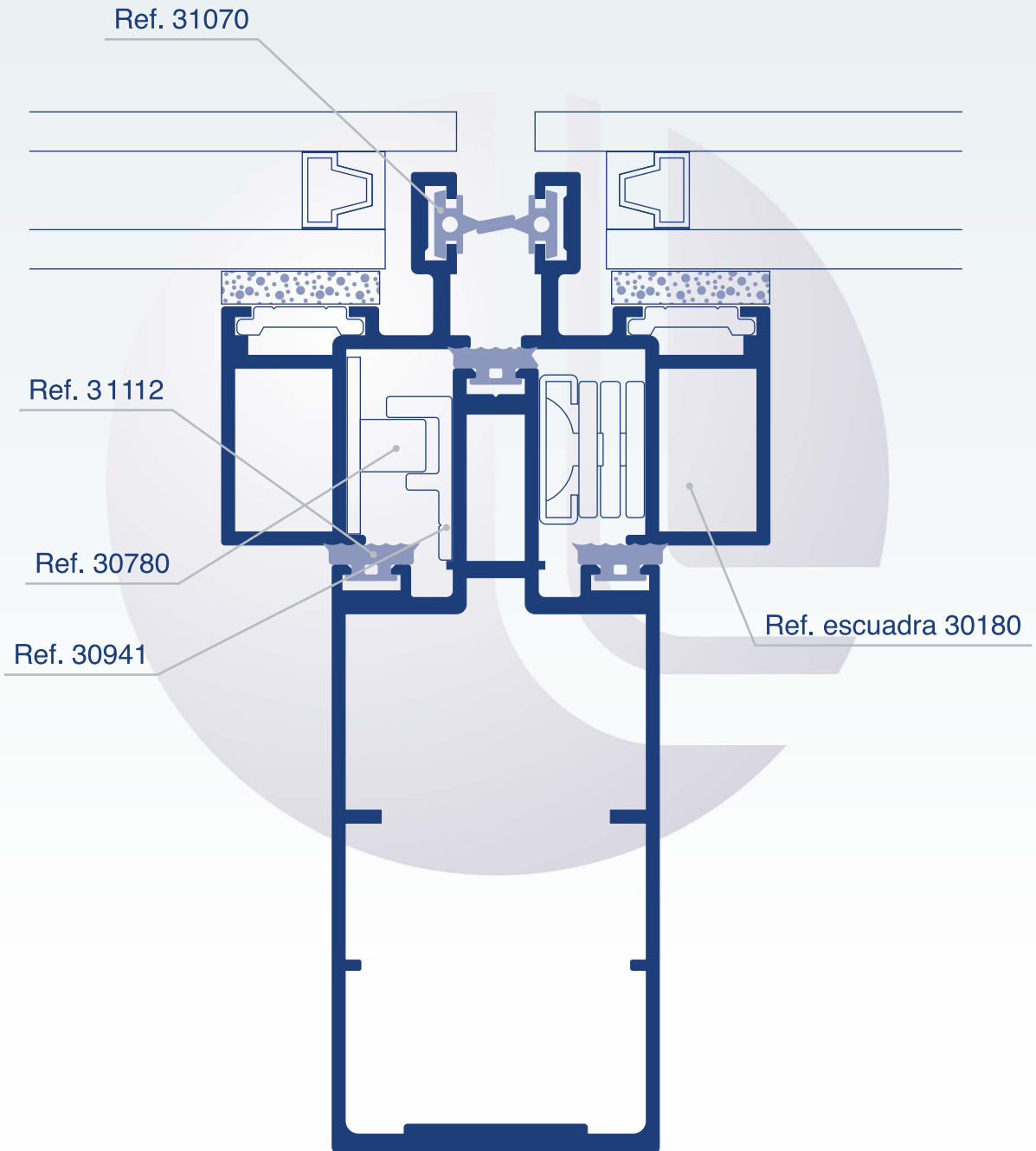
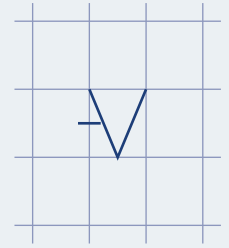

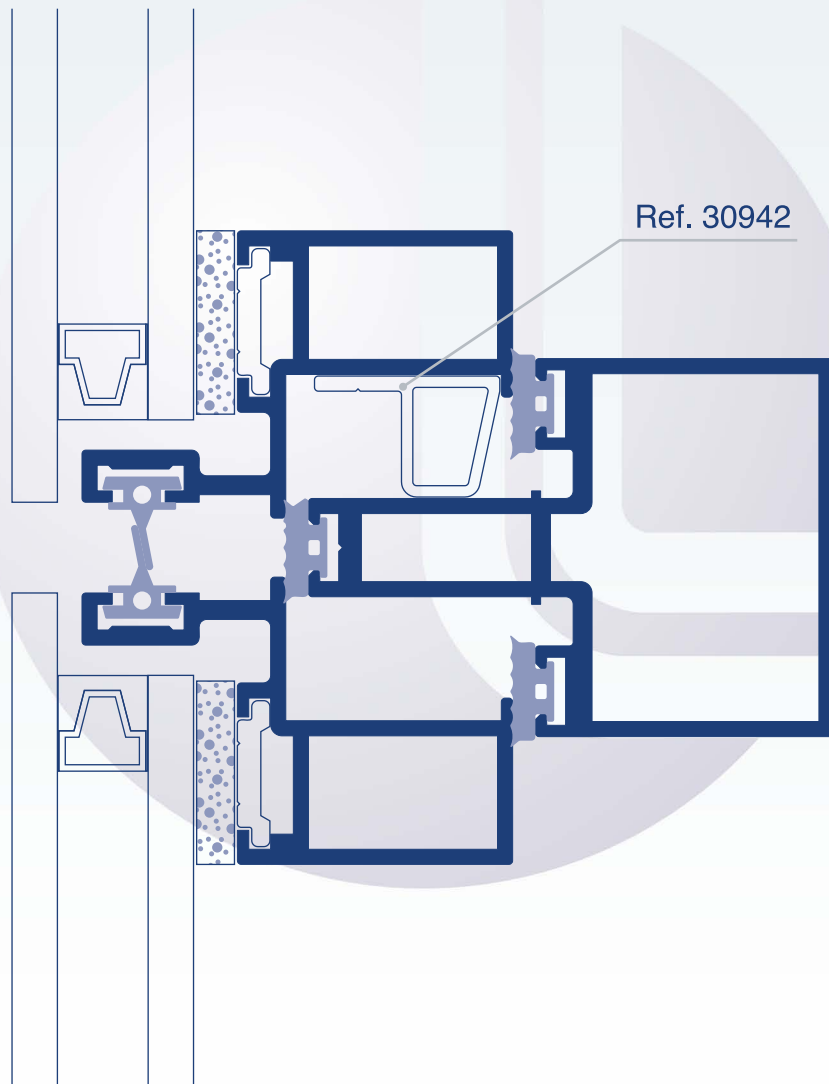
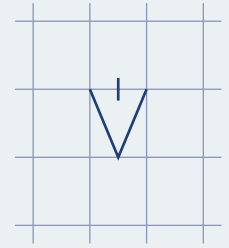

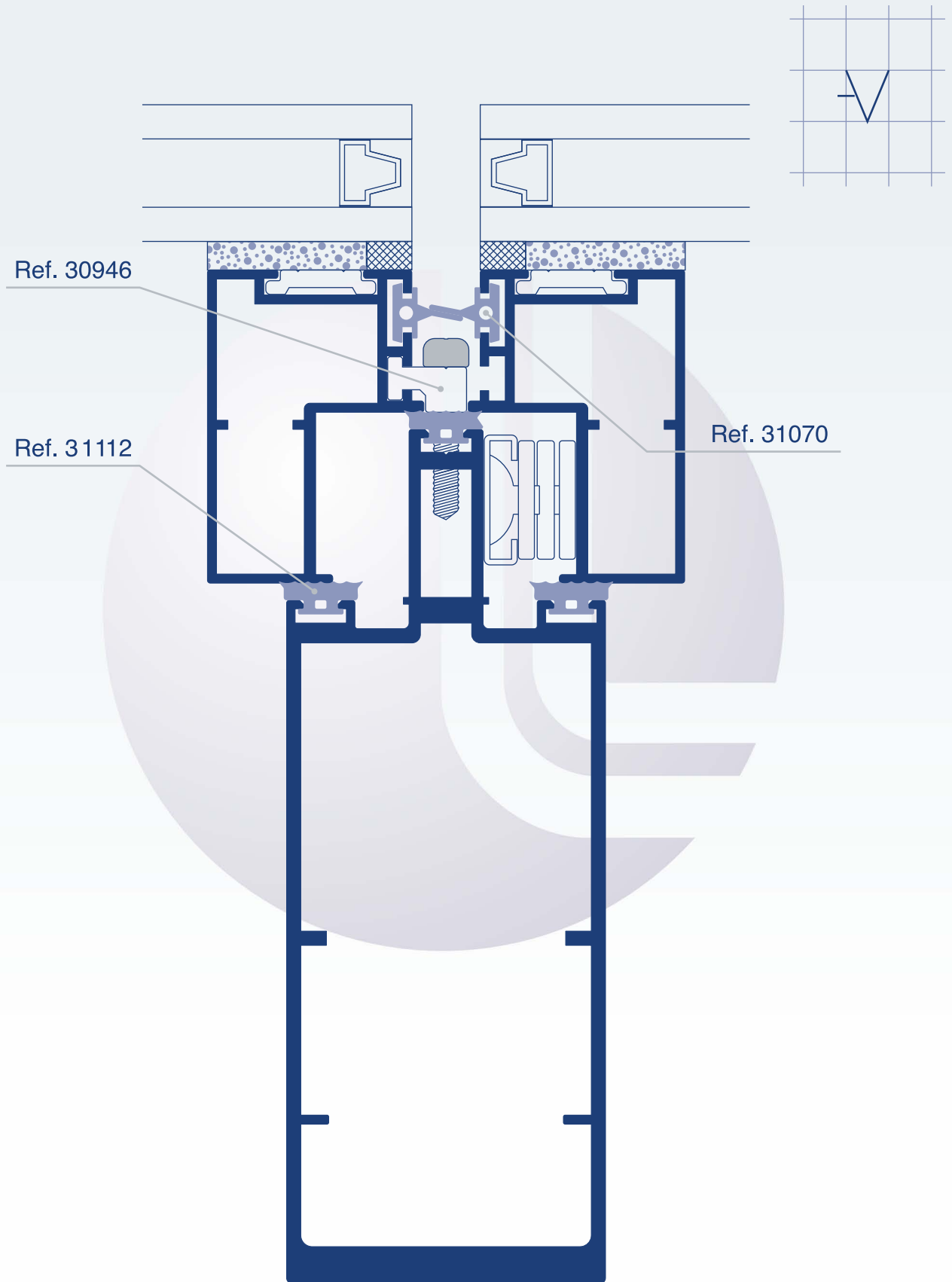

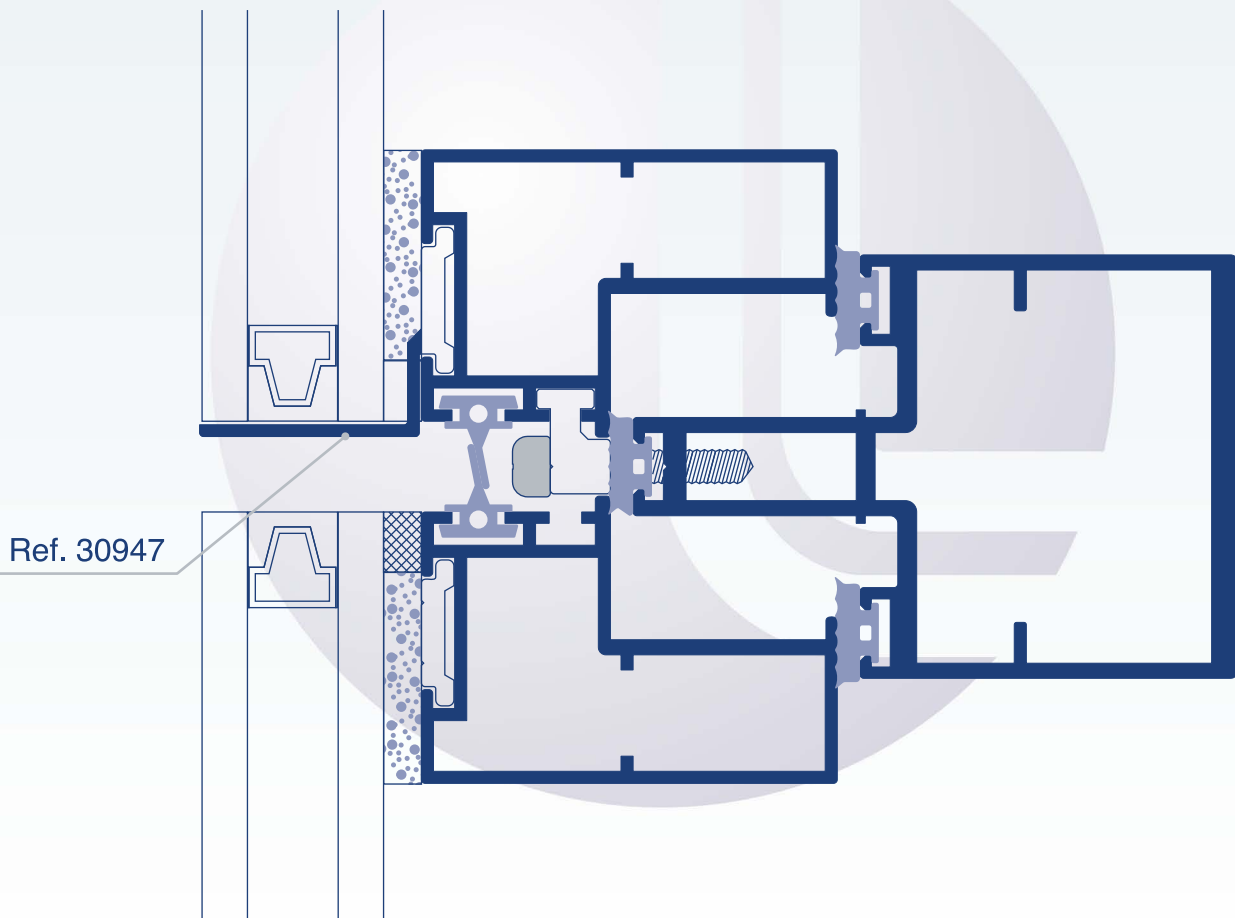
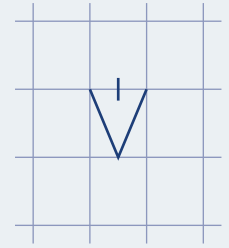

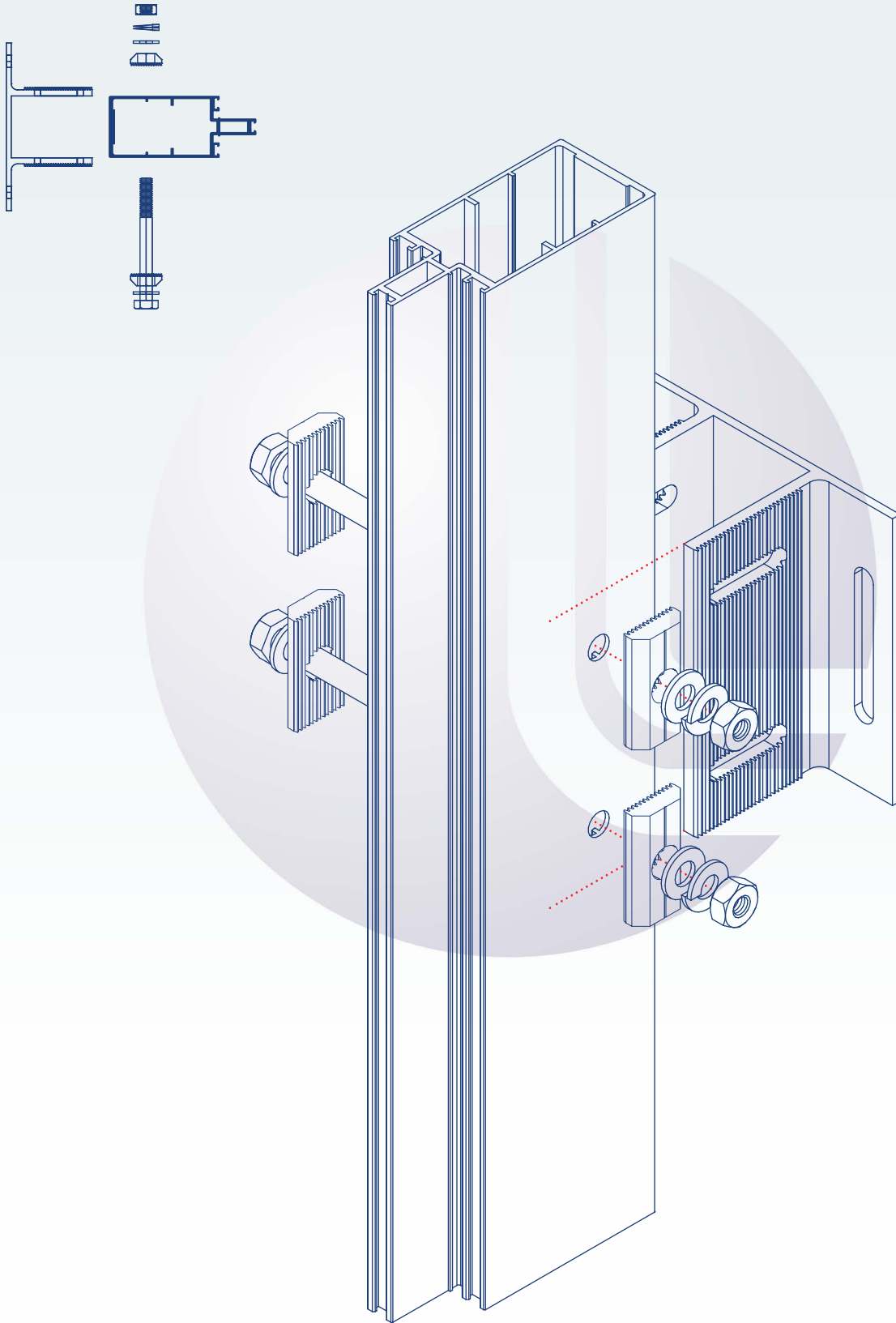

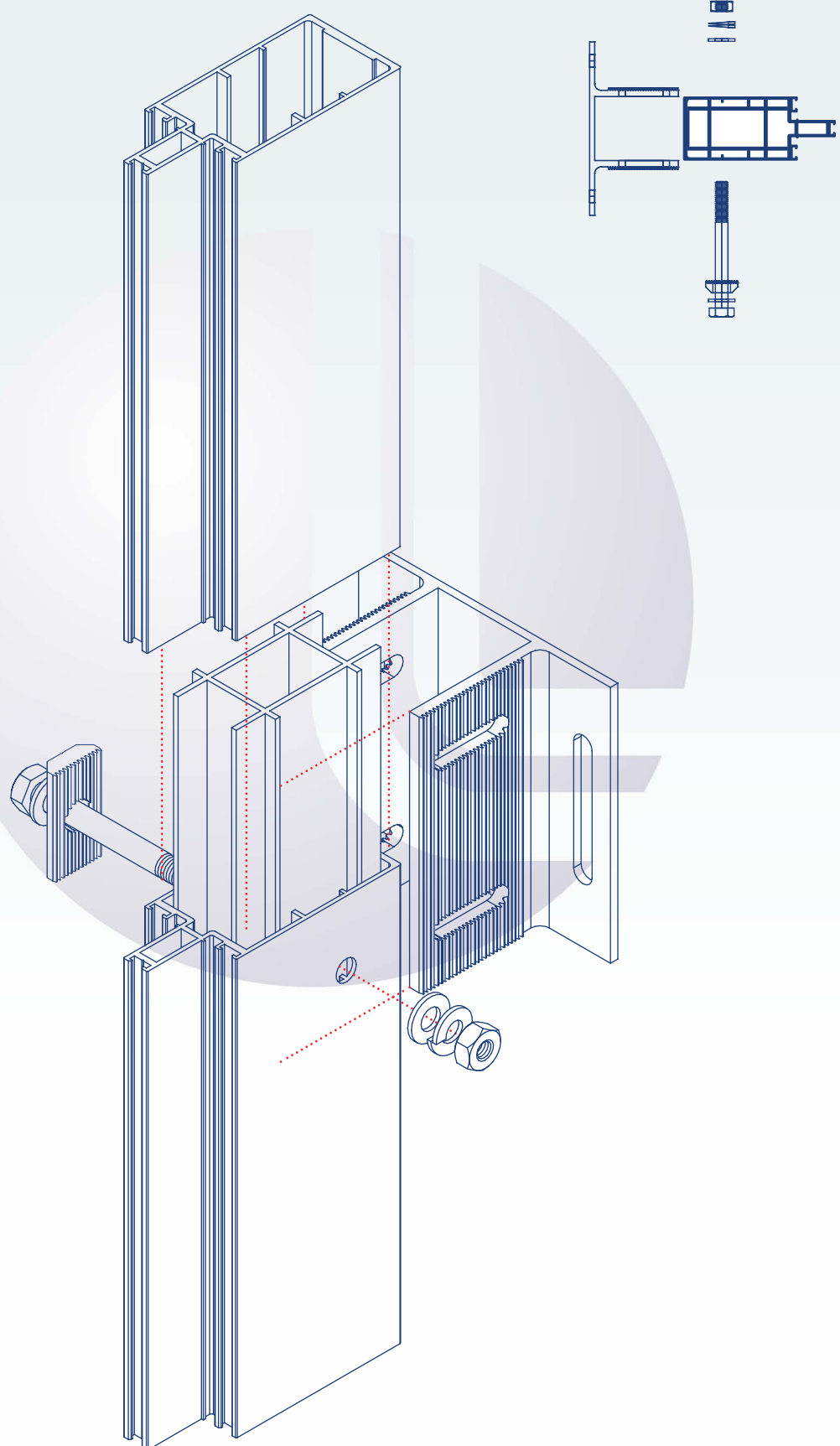

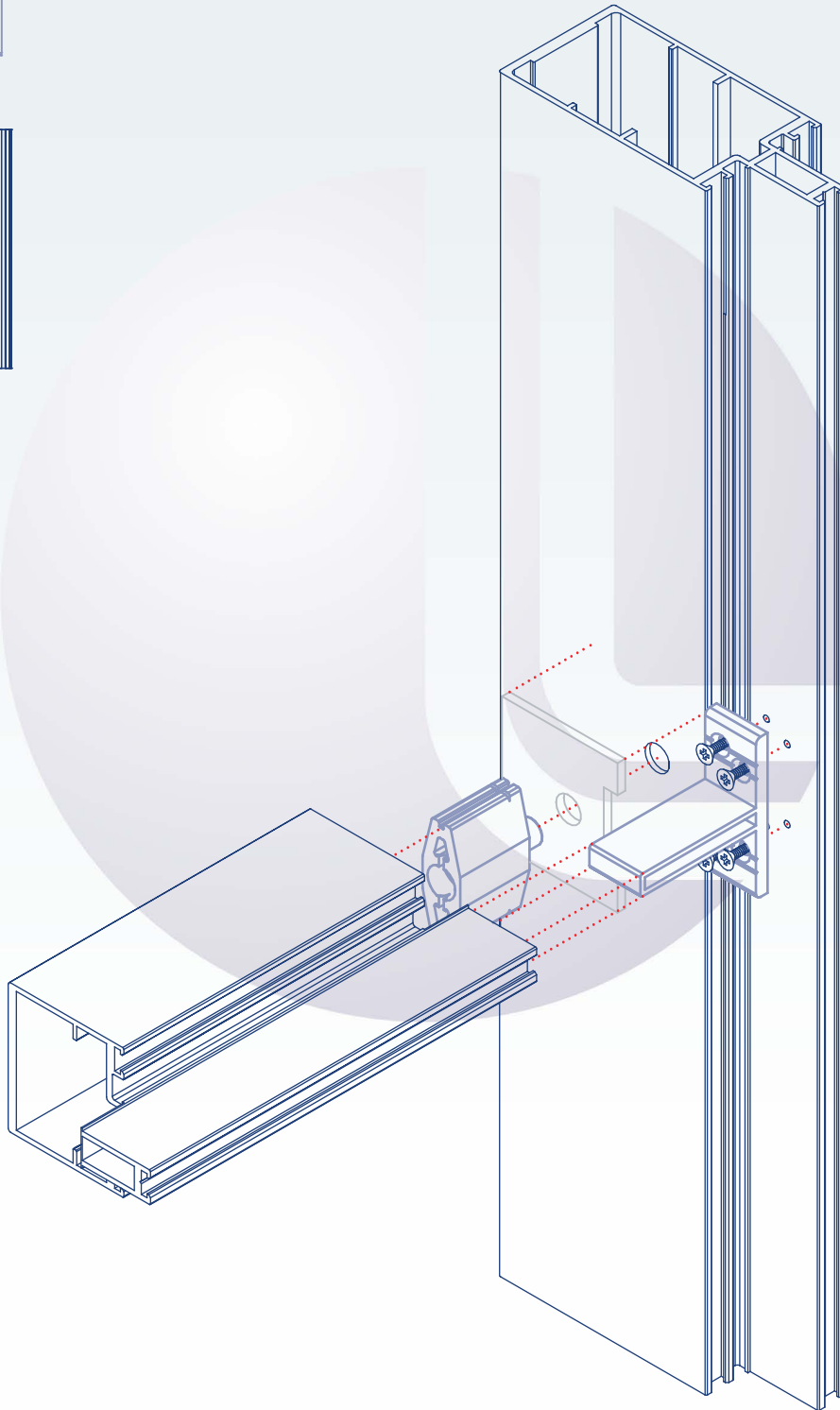
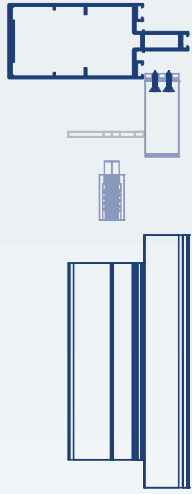

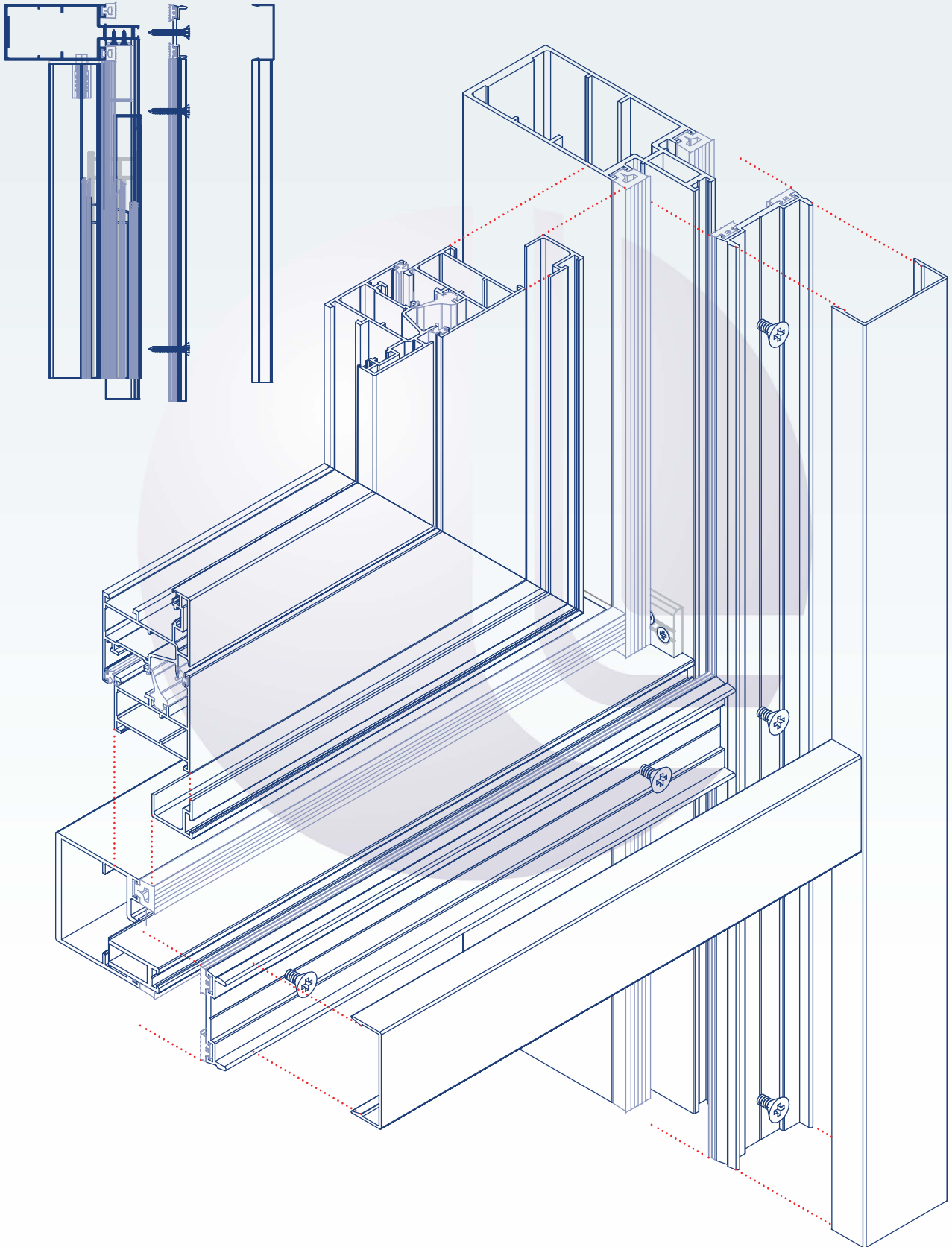

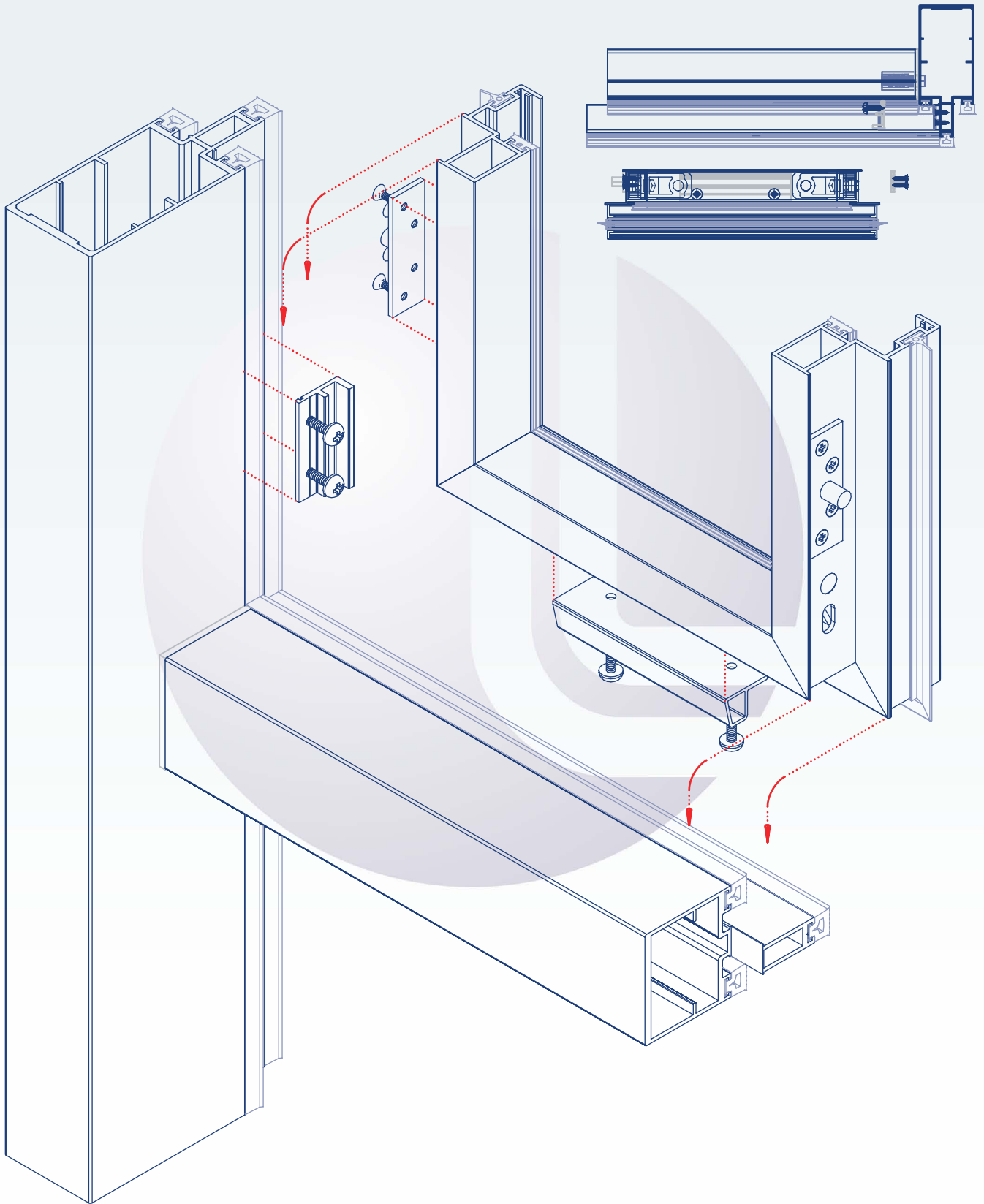

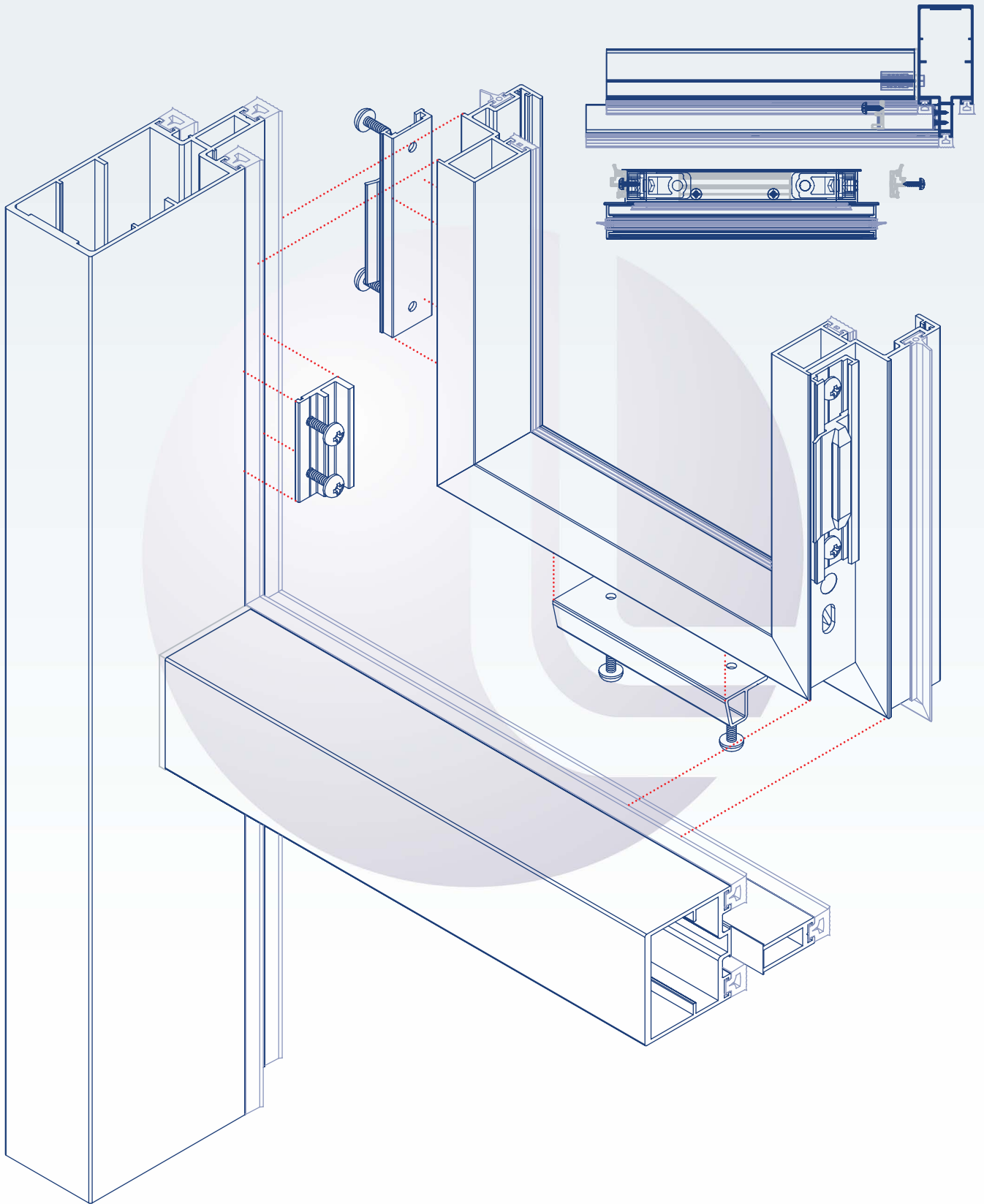

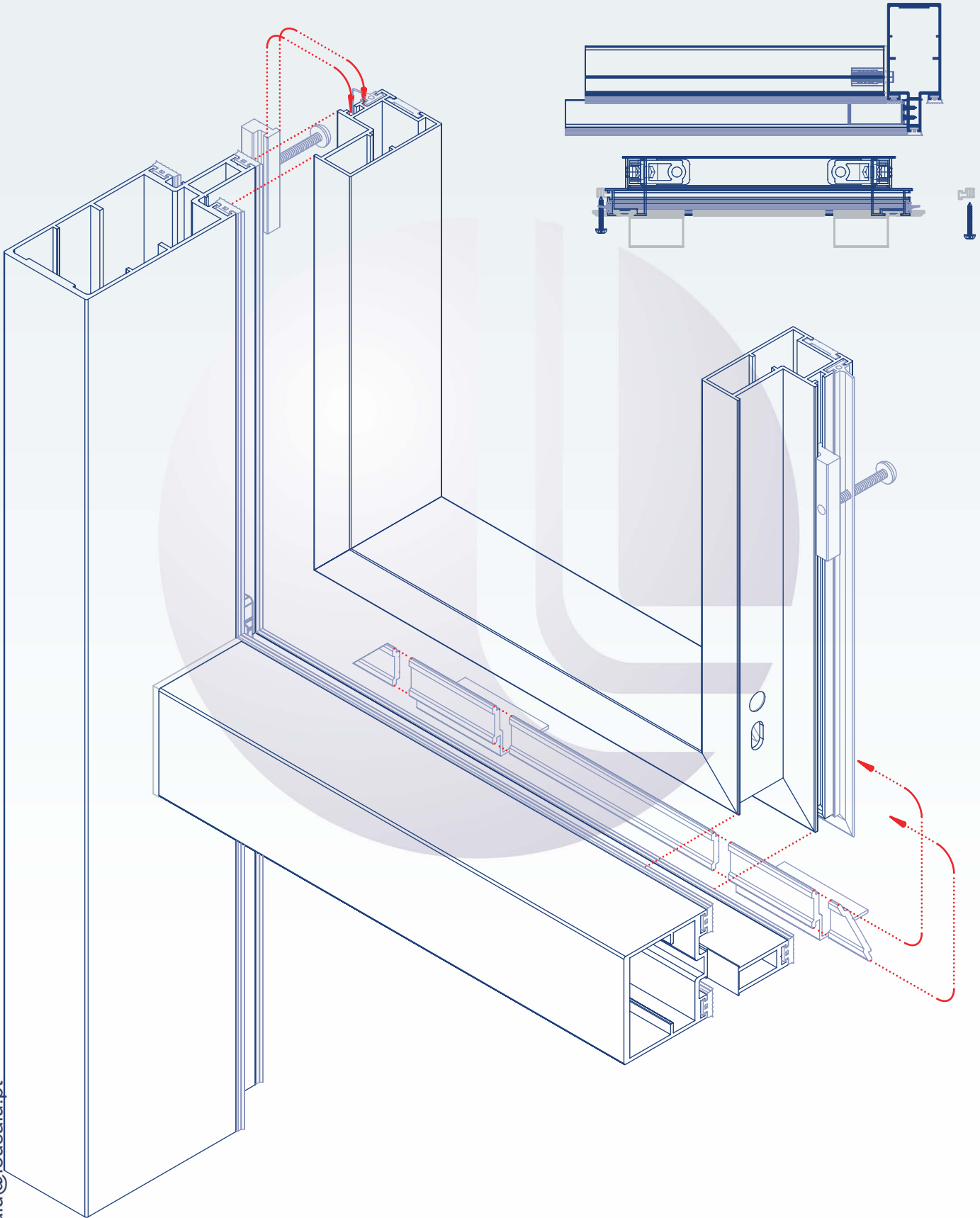

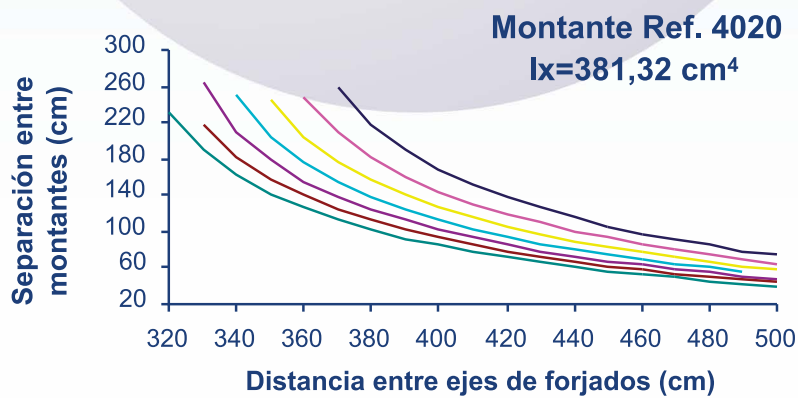
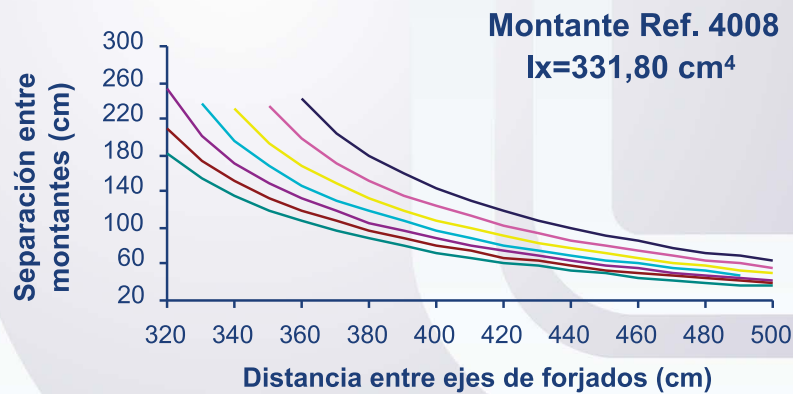
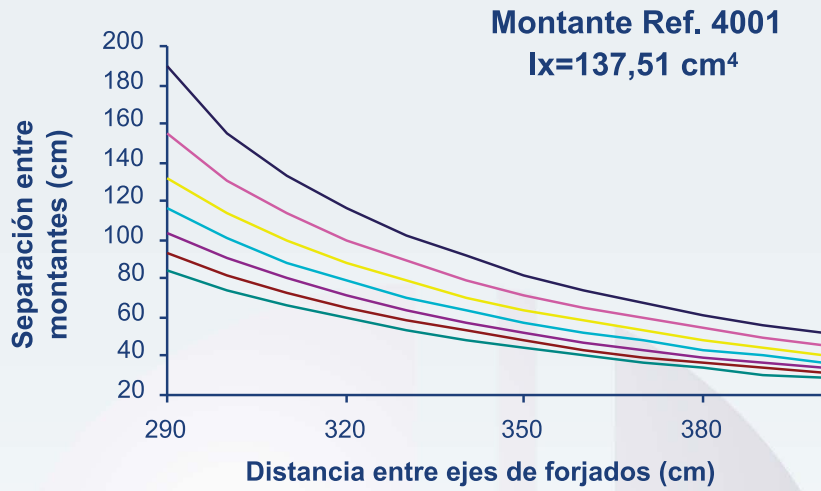

- Presión 80 Kg/m²
- Presión 90 Kg/m²
- Presión 100 Kg/m²
- Presión 110 Kg/m²
- Presión 120 Kg/m²
- Presión 130 Kg/m²
- Presión 140 Kg/m²

NOTA: Estos gráficos son orientativos. Se recomienda realizar el cálculo estático para cada caso concreto.