

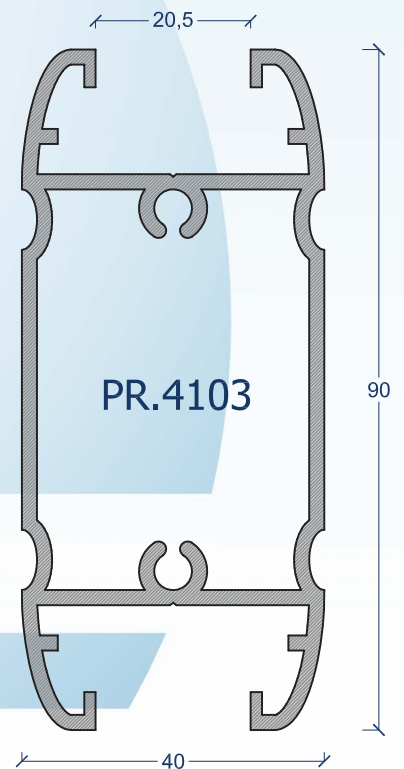

BIG GATES

sistemas de Portões & Gradeamentos

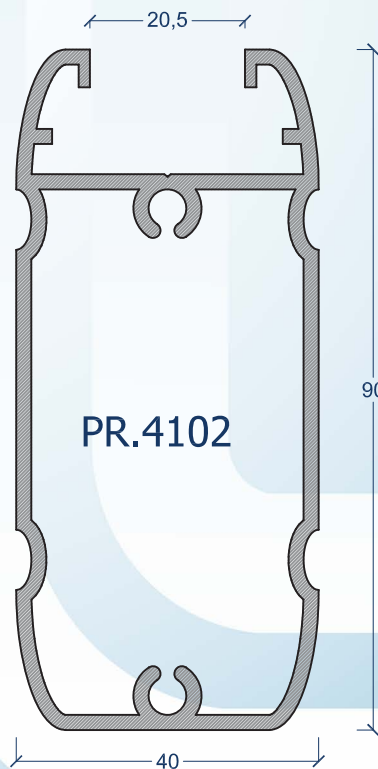

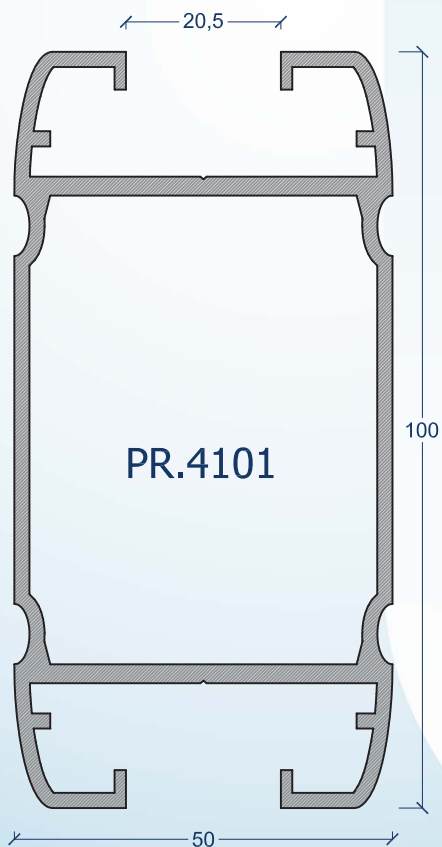
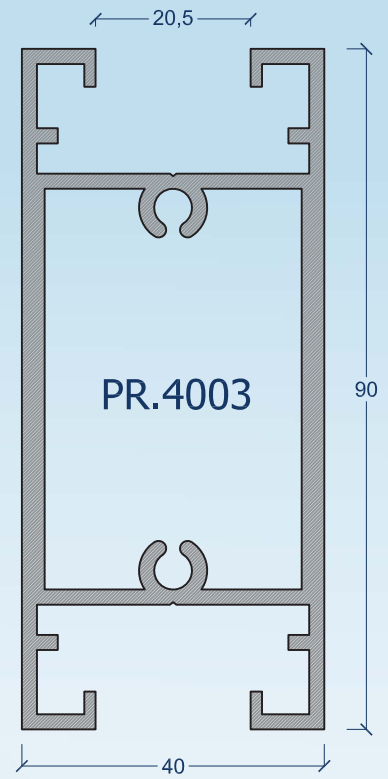
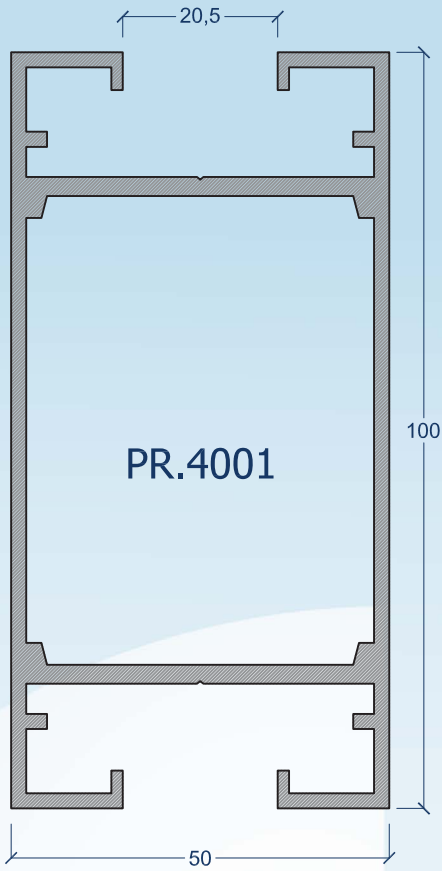

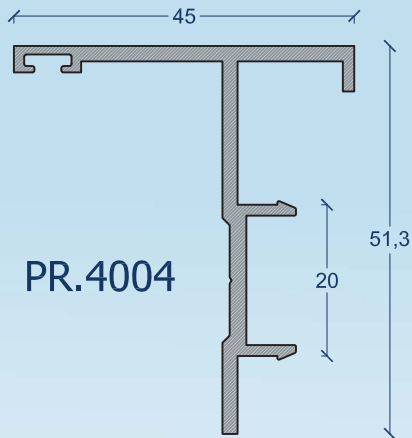

PR.4004

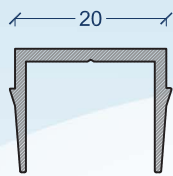

PR.4005

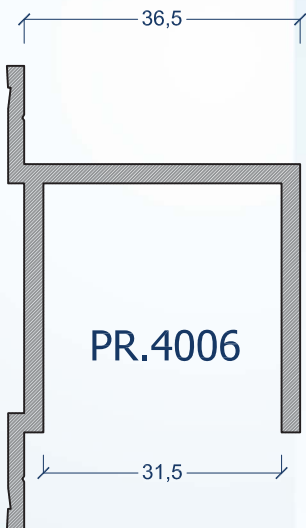

PR.4006

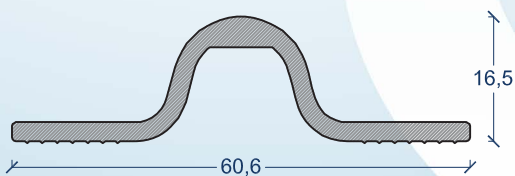

PR.4009

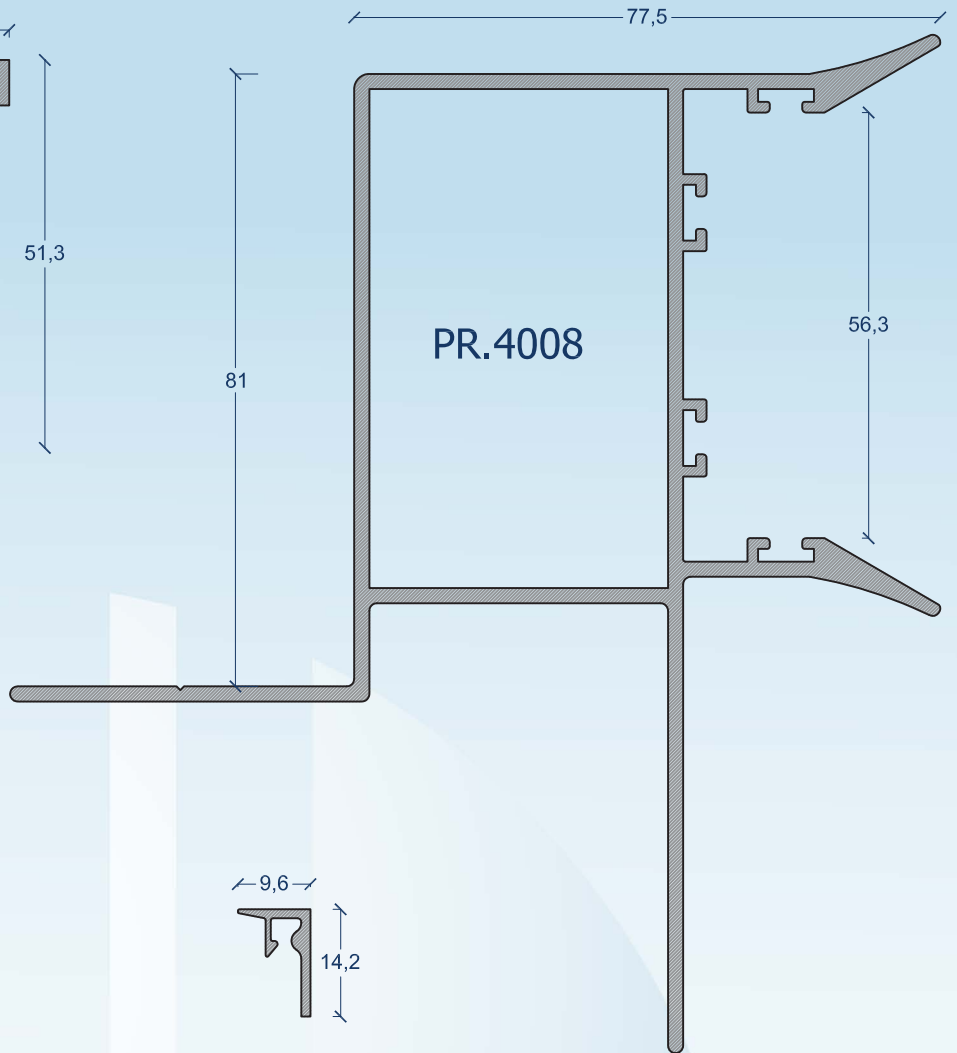

PR.4008

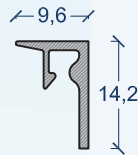

PR.4007

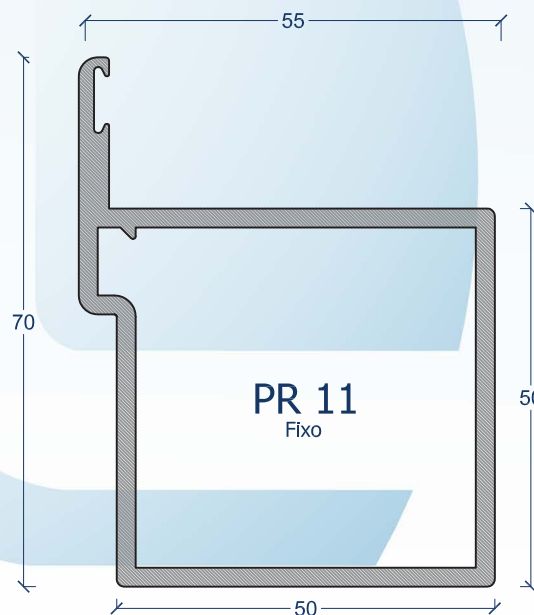

PR 11
Fixo

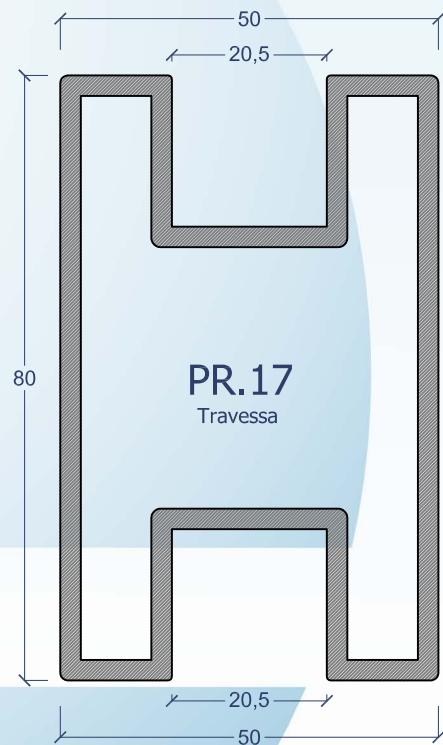
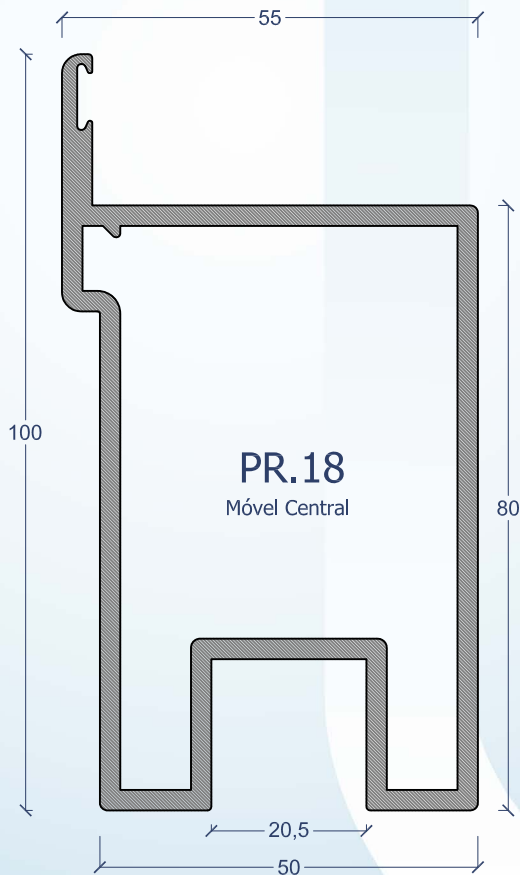
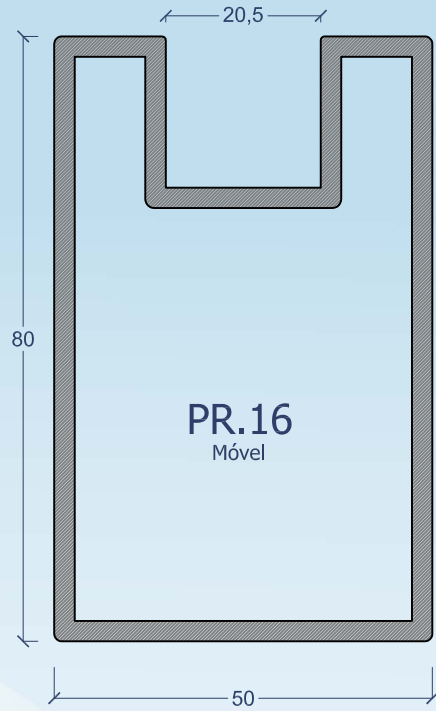
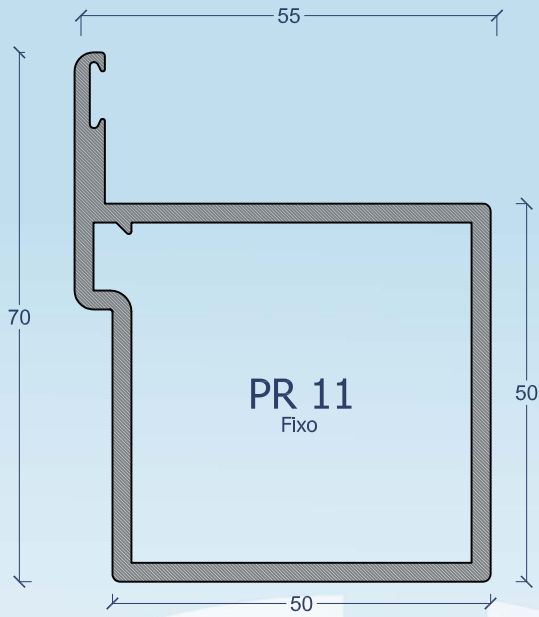

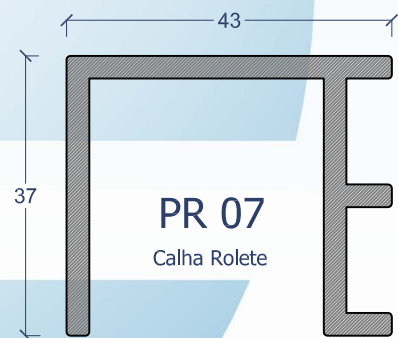
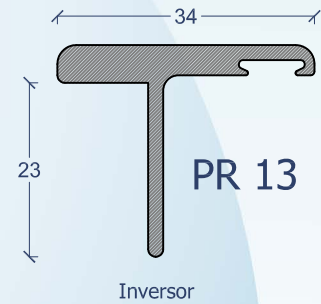
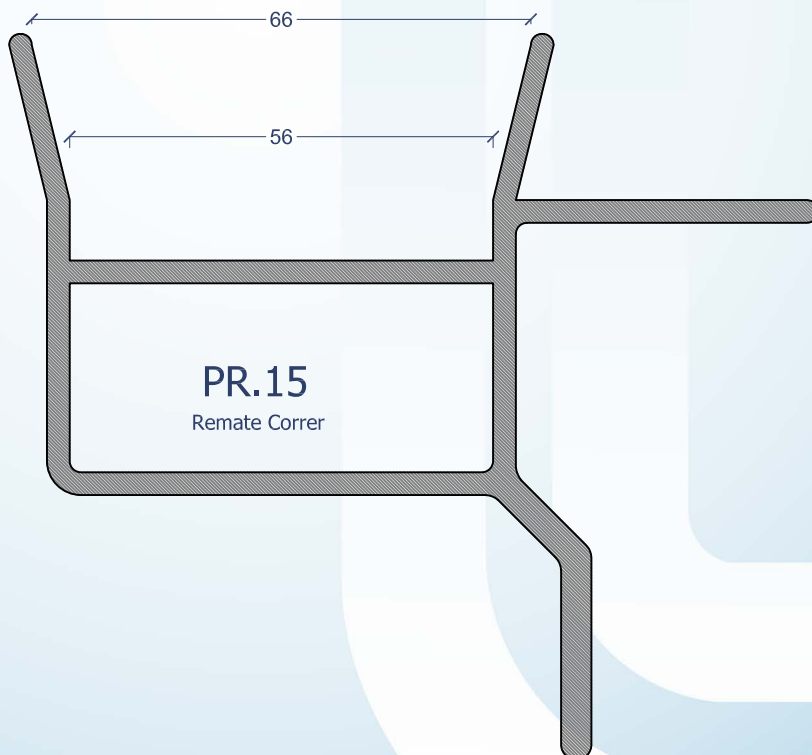
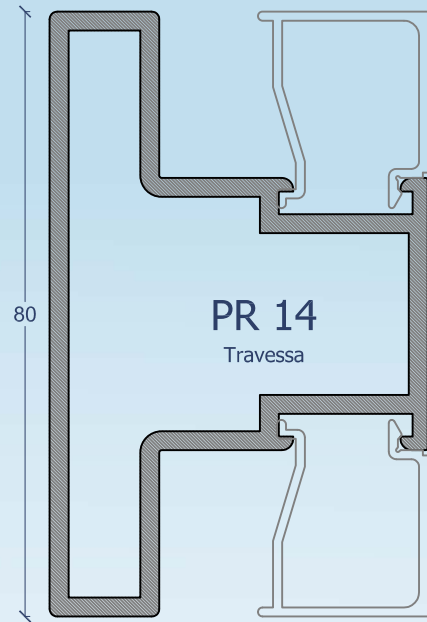
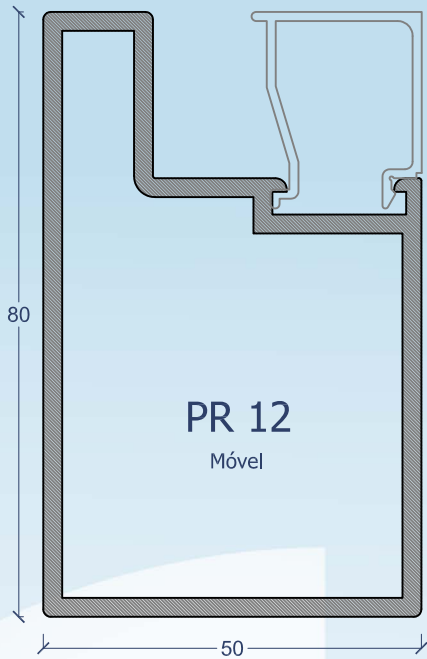

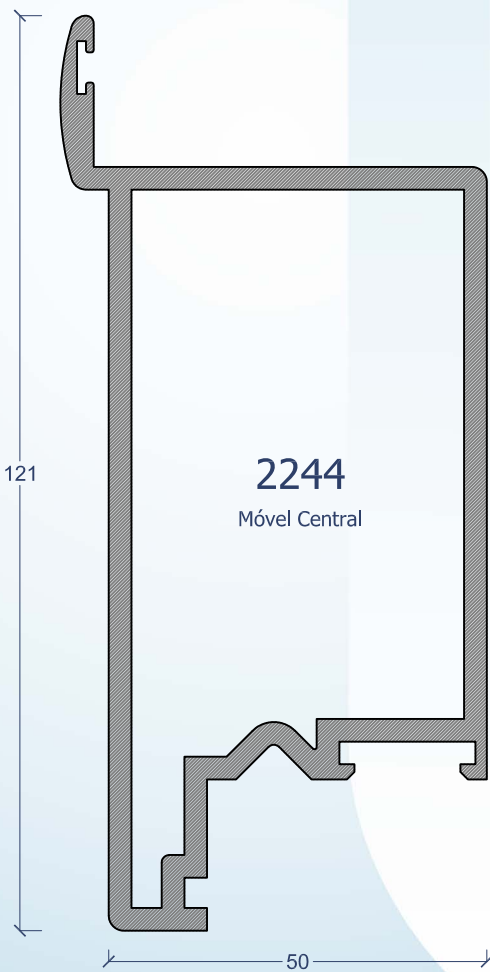
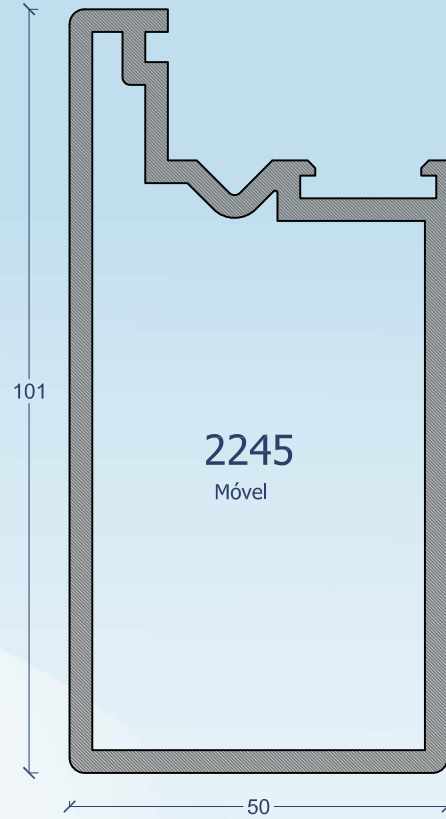
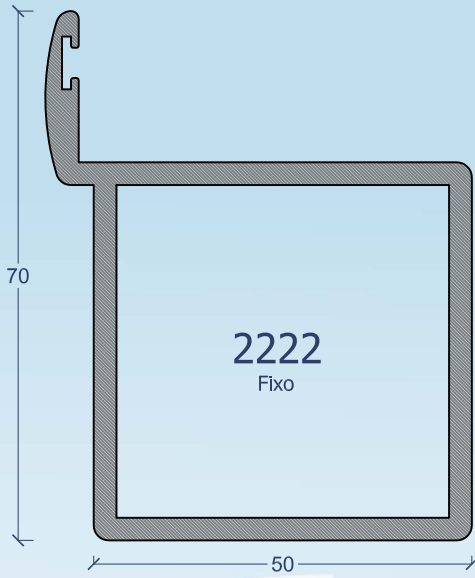

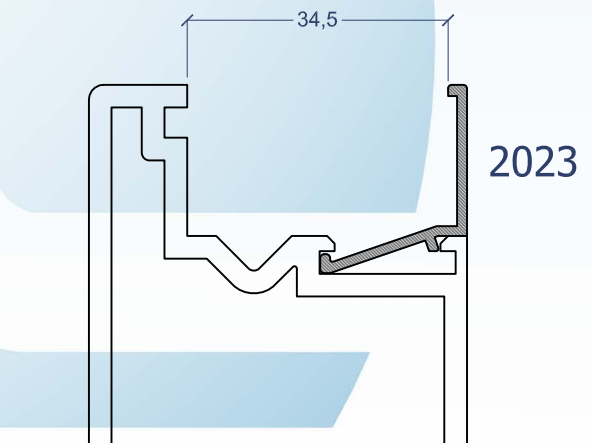
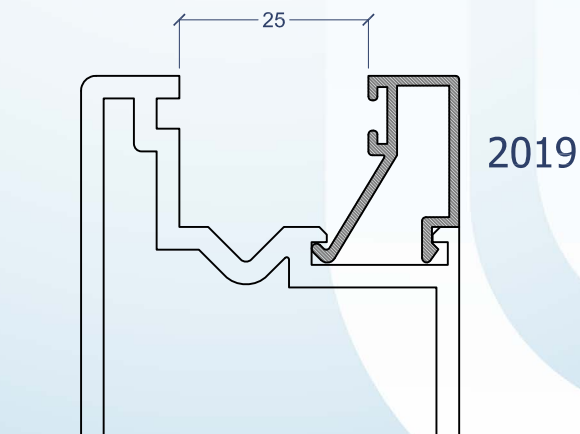
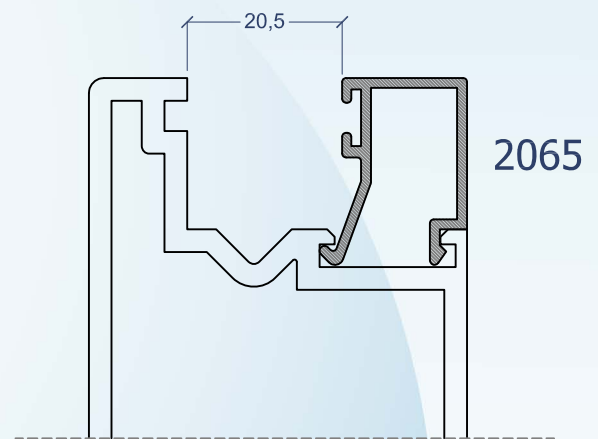
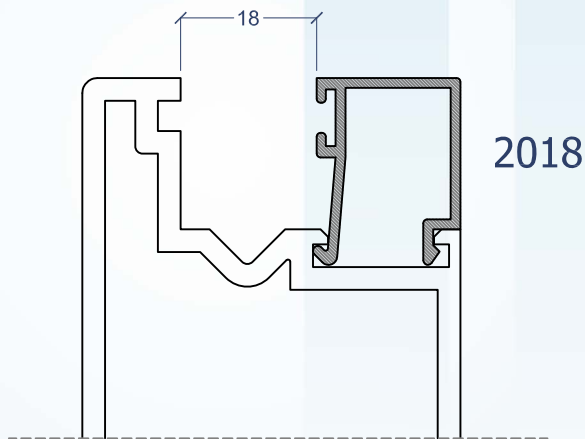
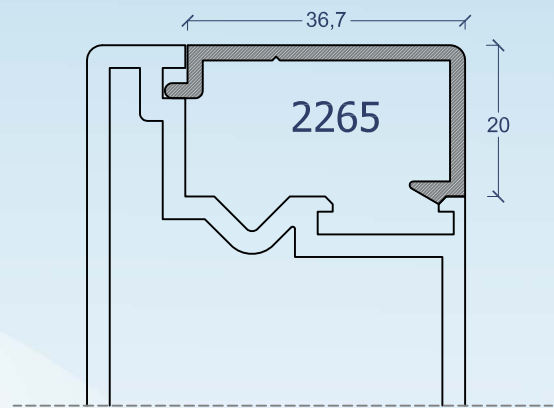
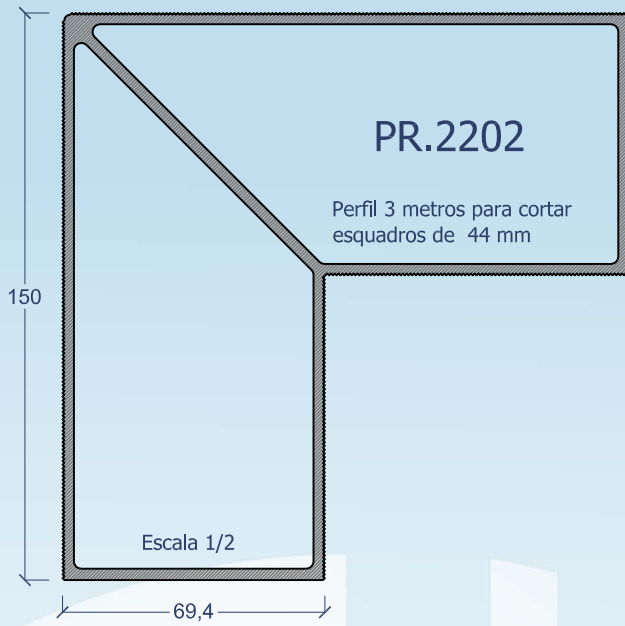

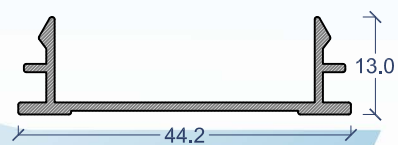
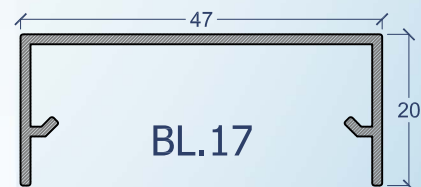
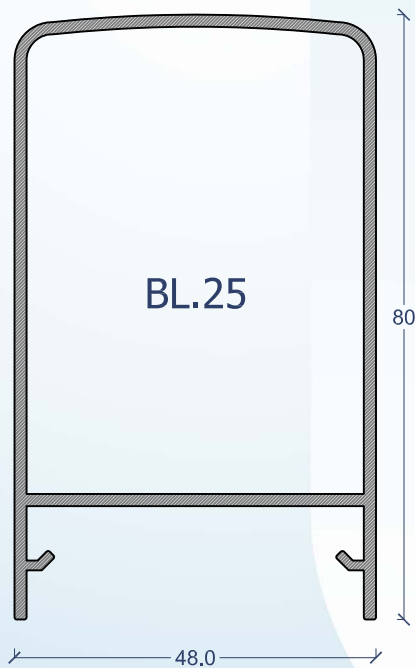
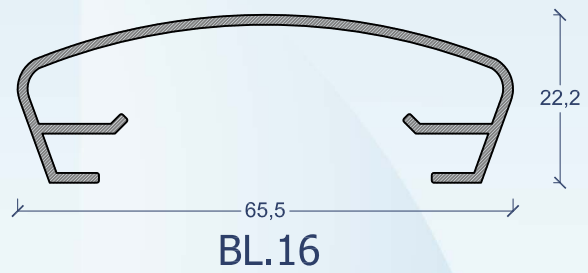
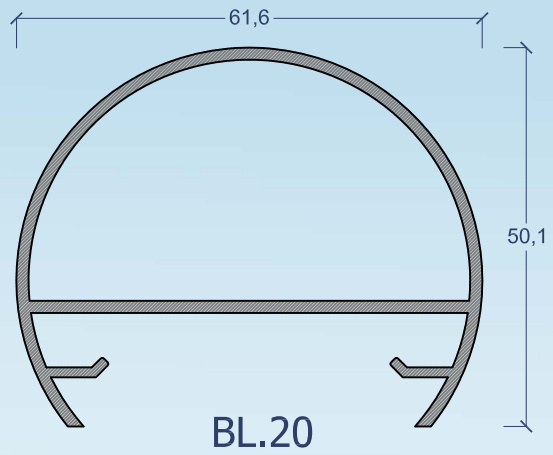
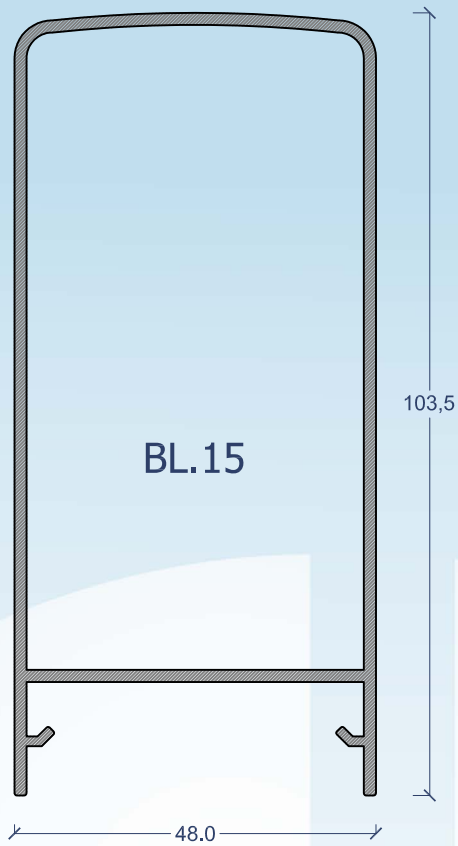

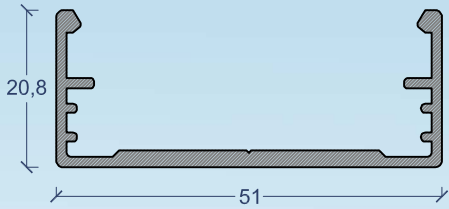

i3500

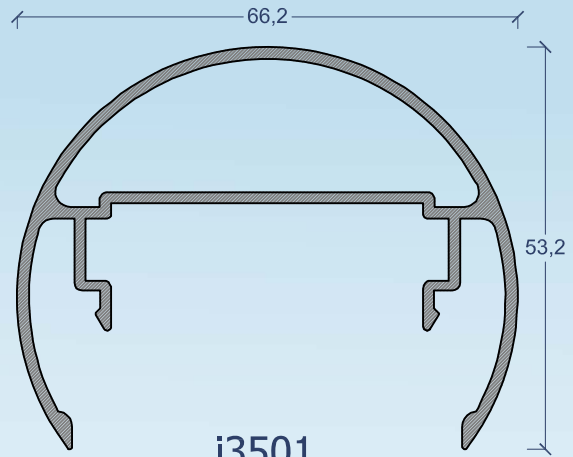

i3501

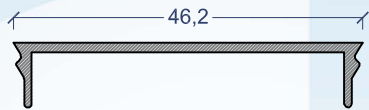

i3504

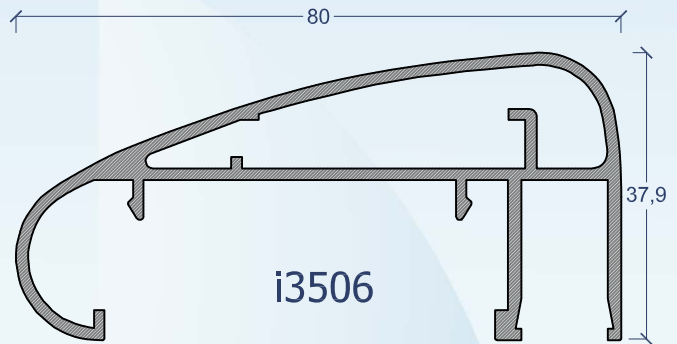

i3506

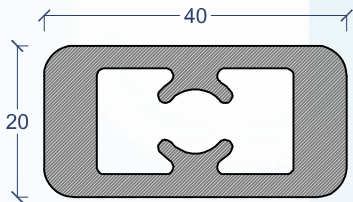

i3502

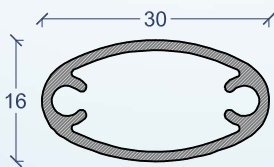

i3508

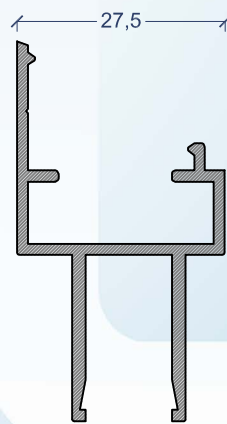

i3507

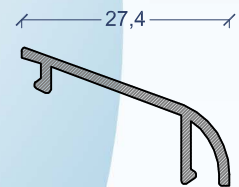

i3505



Laminas de enchimento de aplicação directa

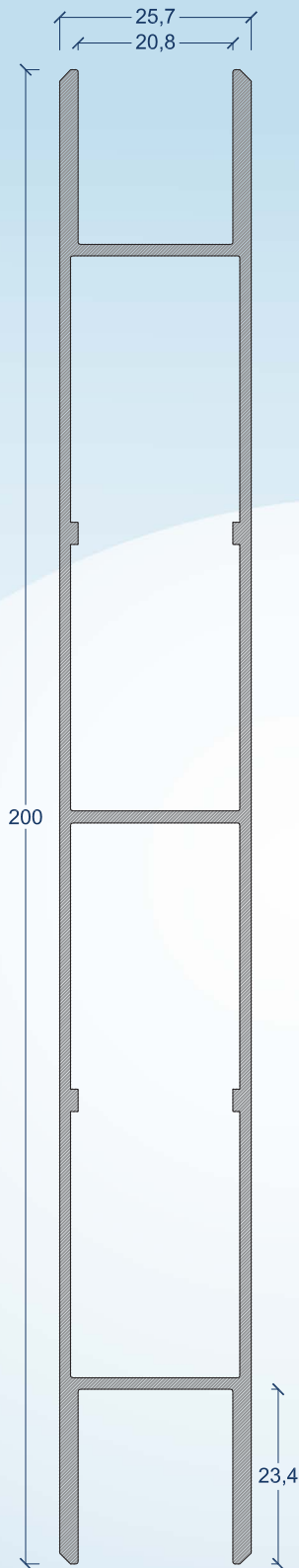

PR.27

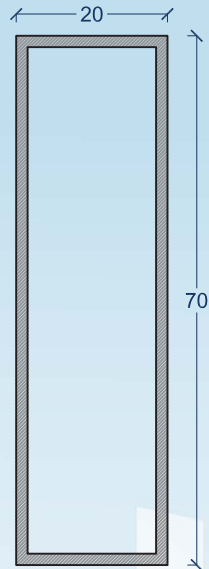

P.37

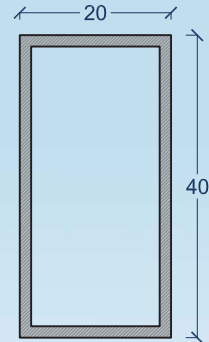

P.04

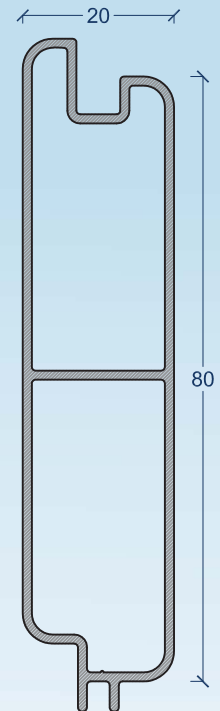

W 28

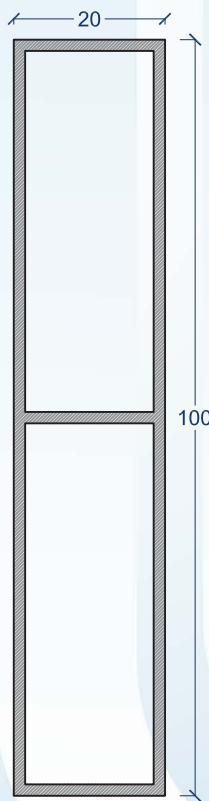

P.14

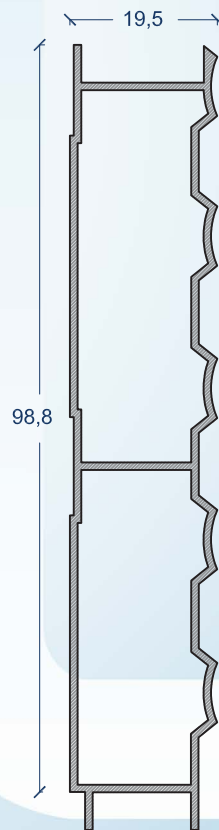

W 21

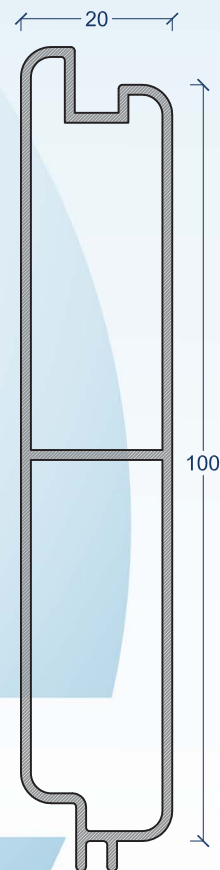

W 25



Perfis de enchimento de aplicação ao PR. 4005

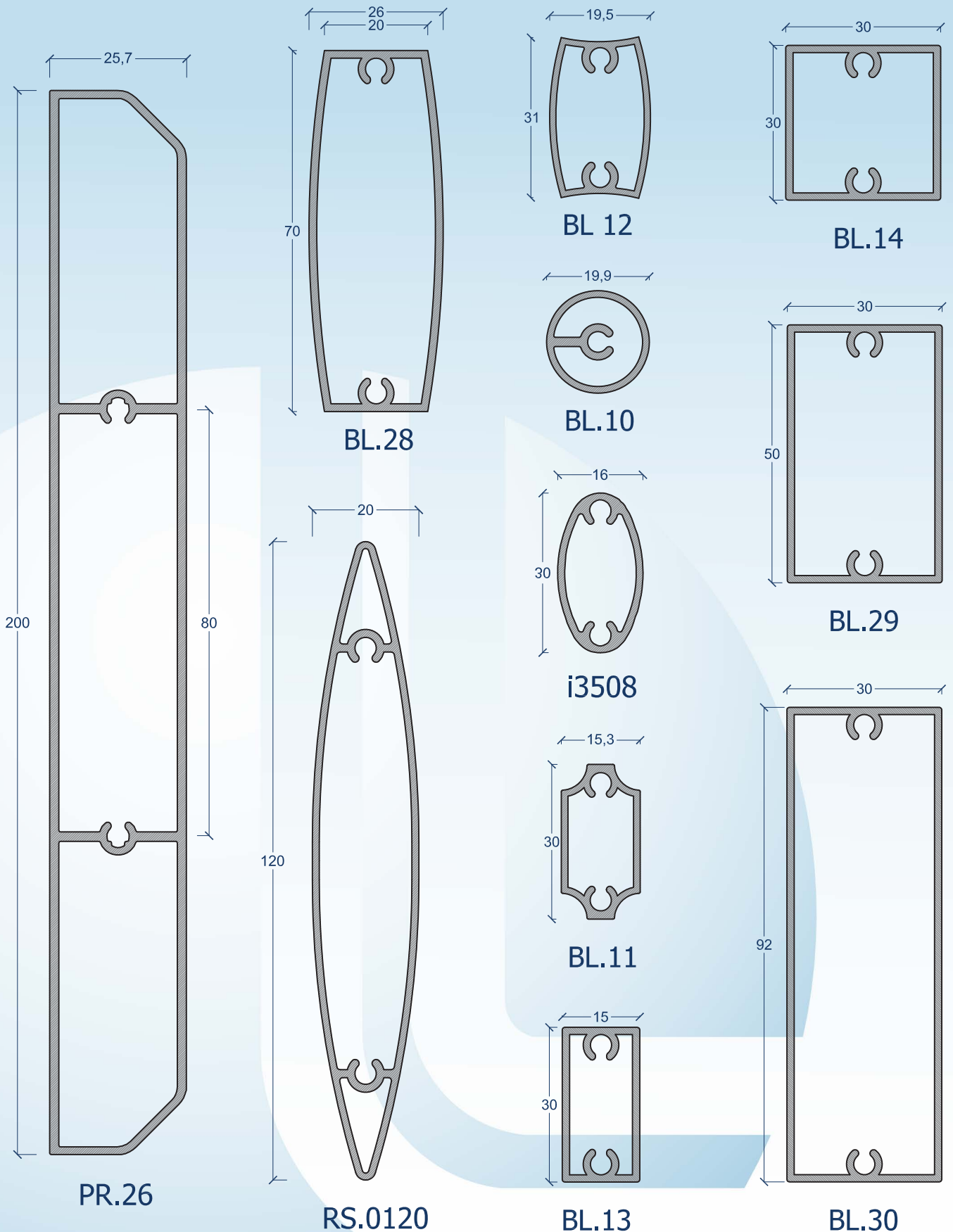

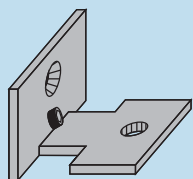

X.18.0027

Uni.

União Montante /Travessa

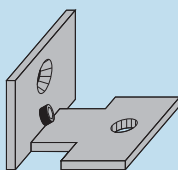

X.18.0028

Uni.

União Travessa /Travessa

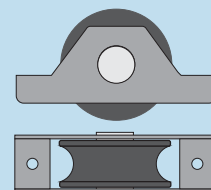

X.28.0062

Uni.

Rolamento portões de correr



X.54.0046

Uni.

Tampa e sapata para montantes

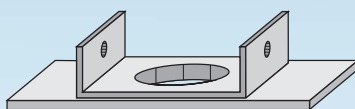

X.54.0047

Uni.

Tampa de montante dobradiça pivotante

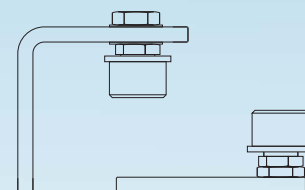

X.29.0015

Kit

Dobradiça portões pivotantes

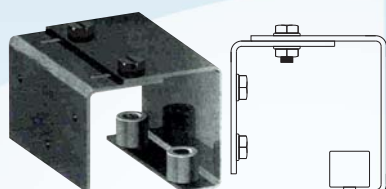

X.52.0113

Uni.

Guia Portões de Correr

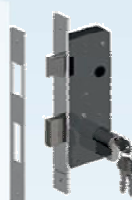

X.38.2032

Uni.

Fechadura prumo portões de Batente

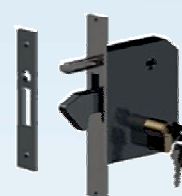

X.38.2033

Uni.

Fechadura prumo portões de Correr

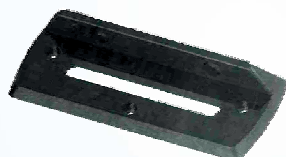

X.52.0114

Uni.

Batente de prumo Portões Batente

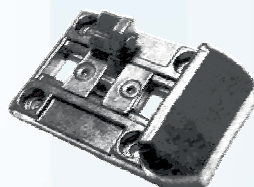

X.52.0115

Uni.

Batente c/fecho 2ª folha Portões Batente

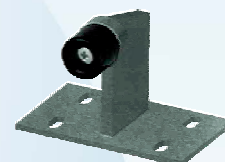

X.52.0117

Uni.

Batente Portões de Correr



X.52.0116

Uni.

Batente de Chão Portões Batente

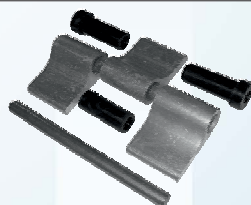

X.24.0007

Uni.

Dobradiça 3 abas para soldar

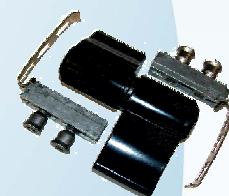

X.24.0010

Uni.

Dobradiça 2 abas aplicação frontal



Pormenor de montagem de portões de correr Com lâmina PR.27

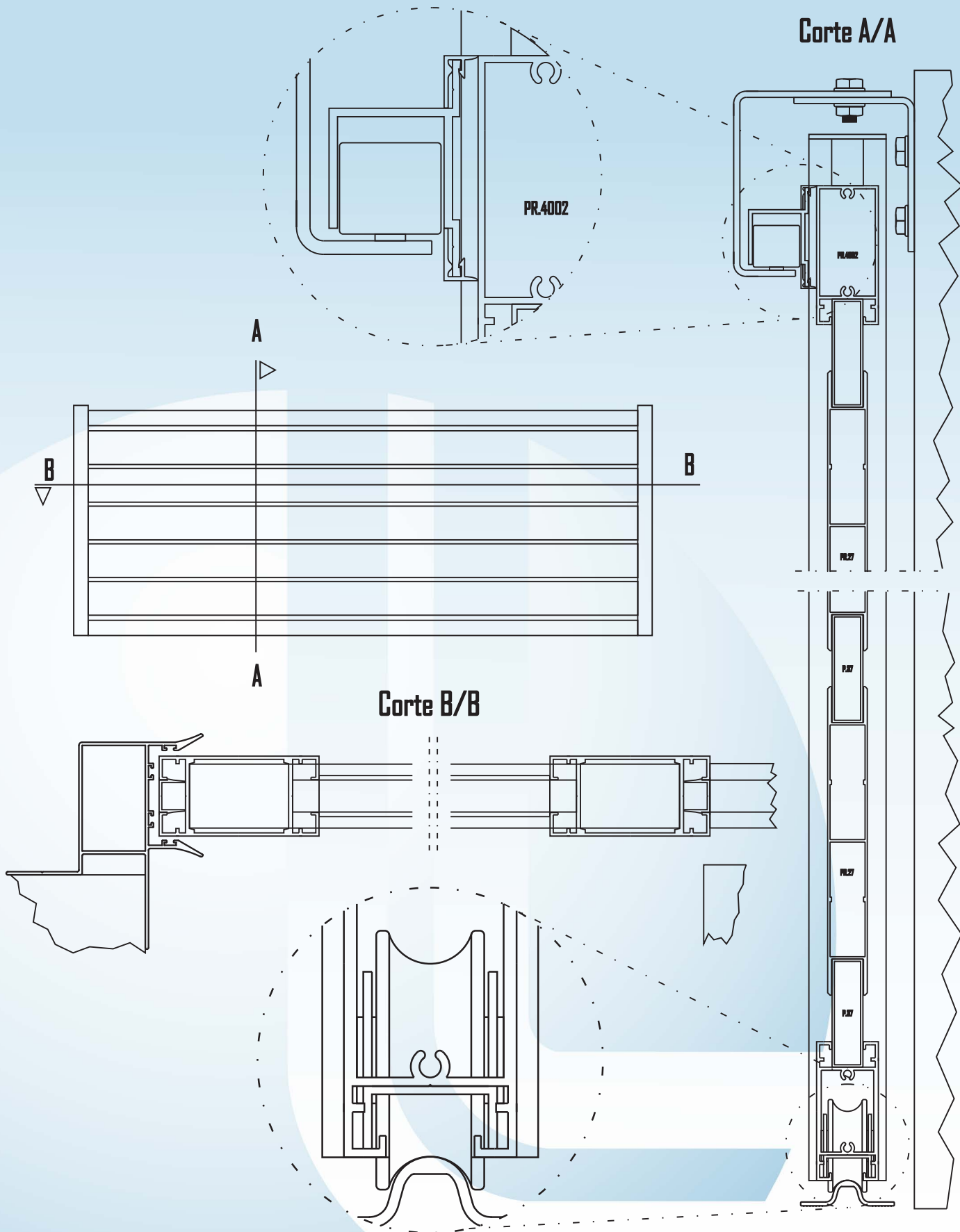



Montagem da travessa com peças de união

A travessa pode ser aplicada de topo ou malhetada conforme os desenhos

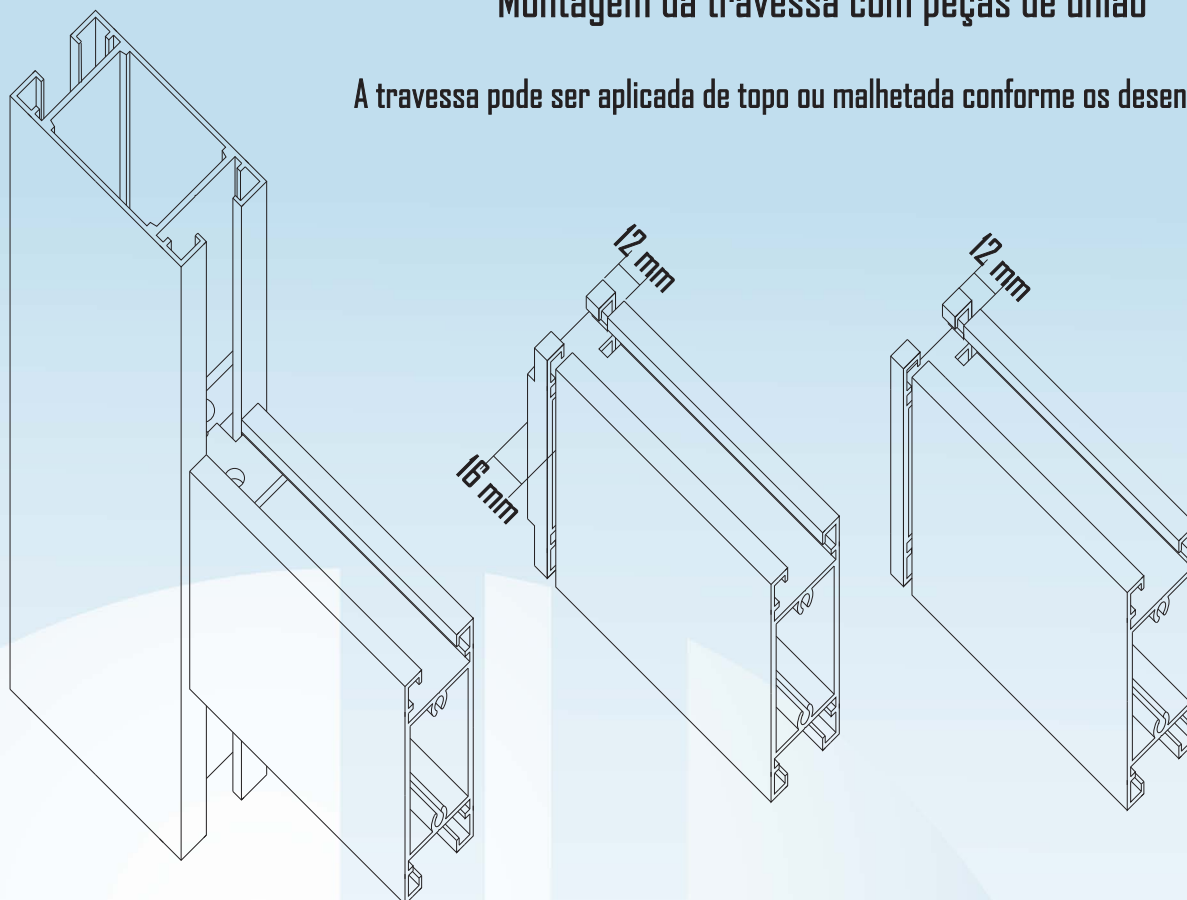

Montagem da travessa com malhete no montante

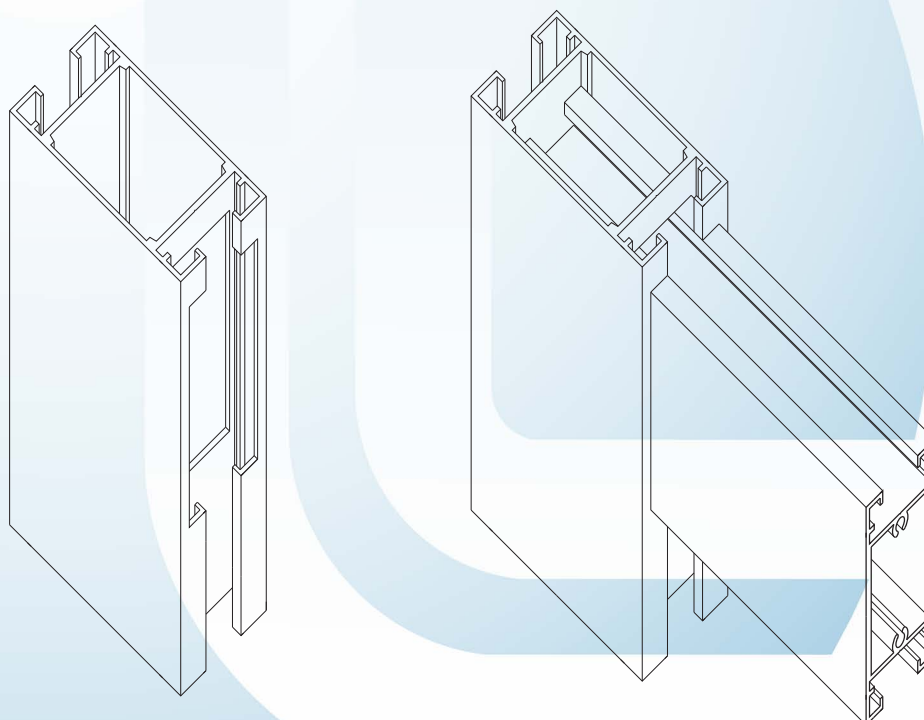



Aspecto da lâmina PR.27

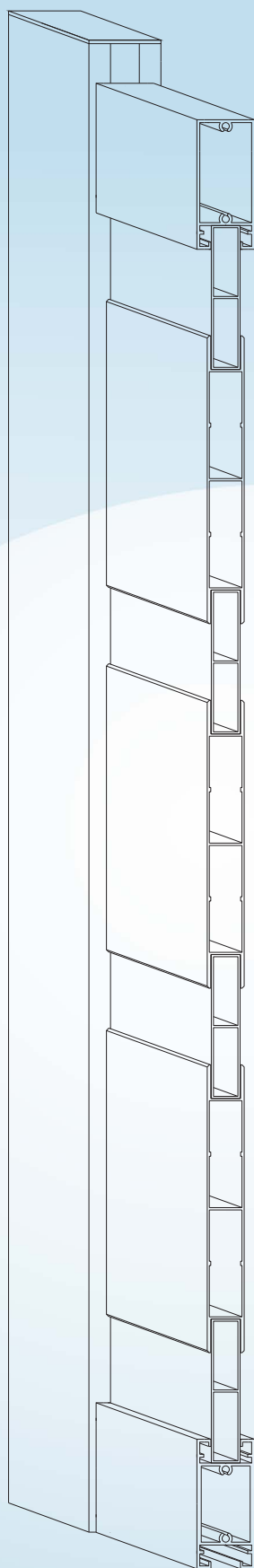

Com tubo 100 x 20mm

Com tubo 60 x 20mm

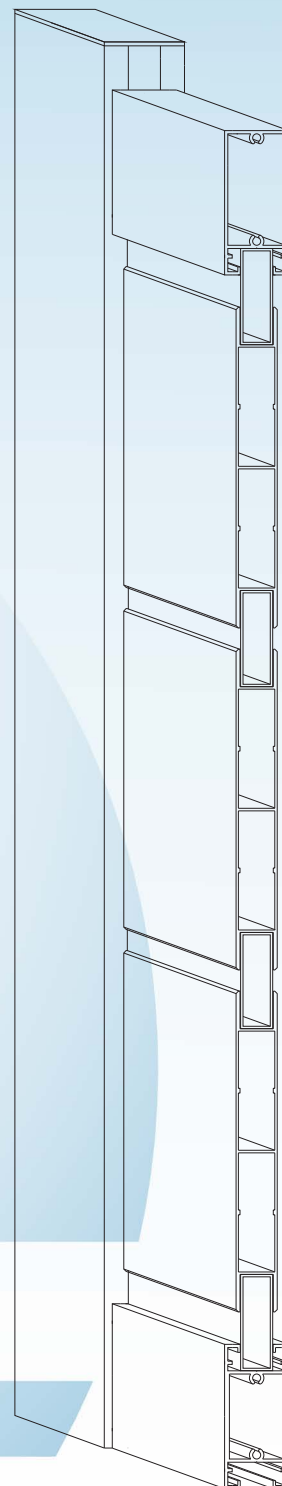

Esta lâmina é aplicada com um tubo de 20mm de largura. A distancia entre lâminas é determinada pela altura do tubo que se pretender usar.

Podem ser feitas combinações de cores ou tratamentos entre a lâmina e o tubo distanciador, por exemplo: Lacado efeito madeira com polido inox.

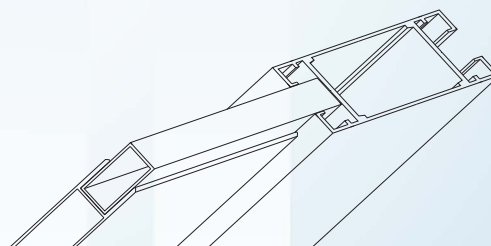

A lâmina é aplicada de topo ao montante e ou travessa, e o tubo distanciador usado para machiar a lâmina, é aplicado por dentro das abas do montante ou da travessa, para fazer a fixação.



Aspecto da aplicação da lâmina PR.26

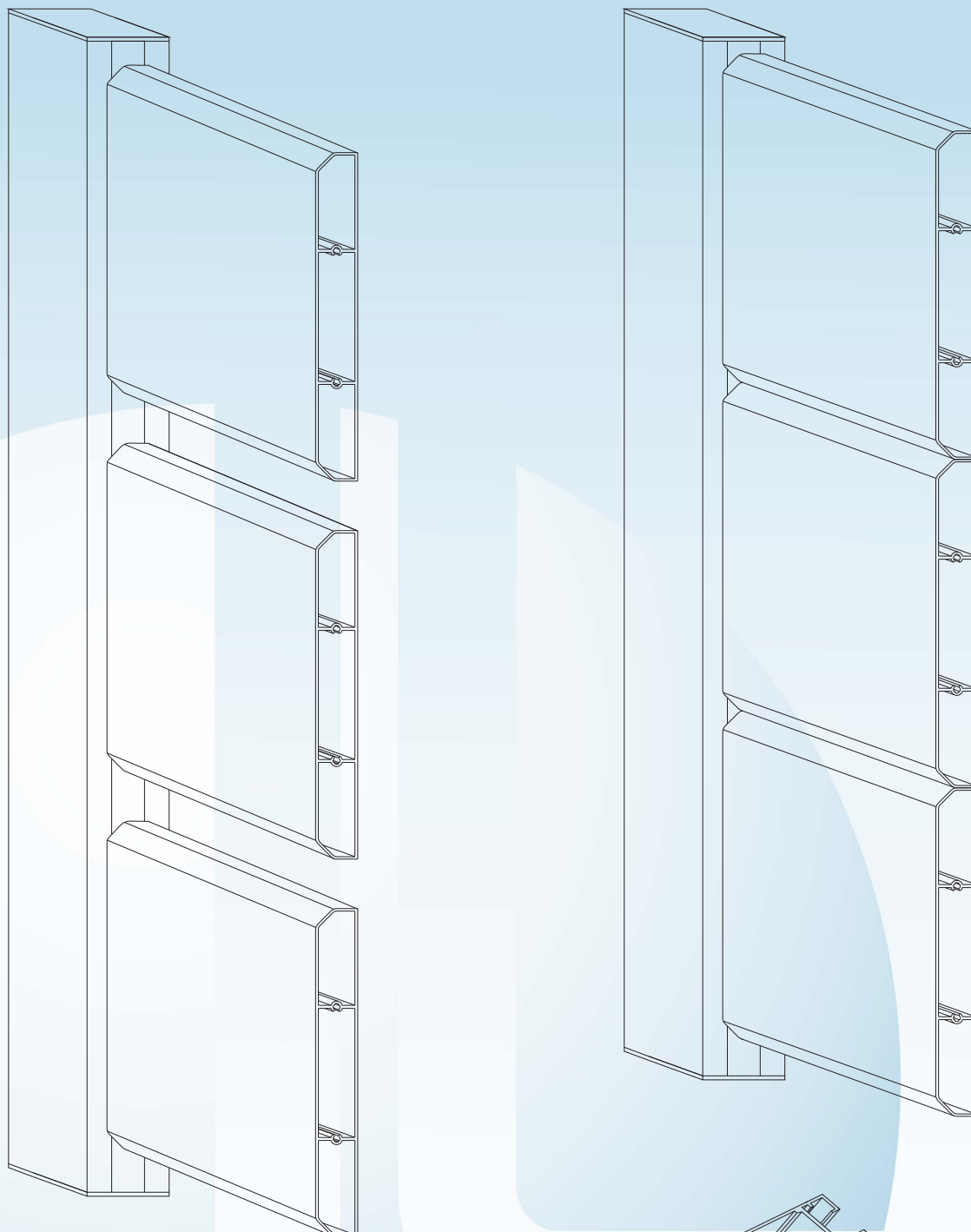

Pormenor da aplicação da lâmina PR.26

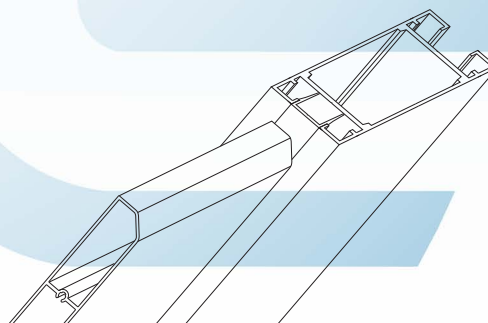



Aspecto da aplicação da lâmina W.25 e Tubulares de 20 mm





Aplicação de perfis tubulares com olhais





Aspecto da aplicação da lâmina RS.0120

