

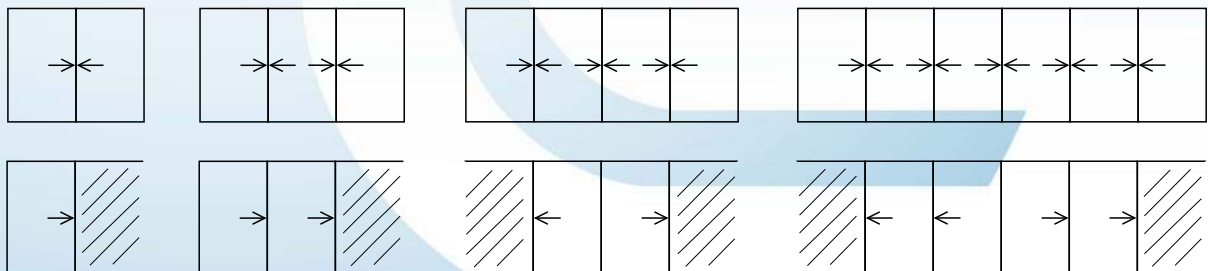

sistema
Le Mans
galandage

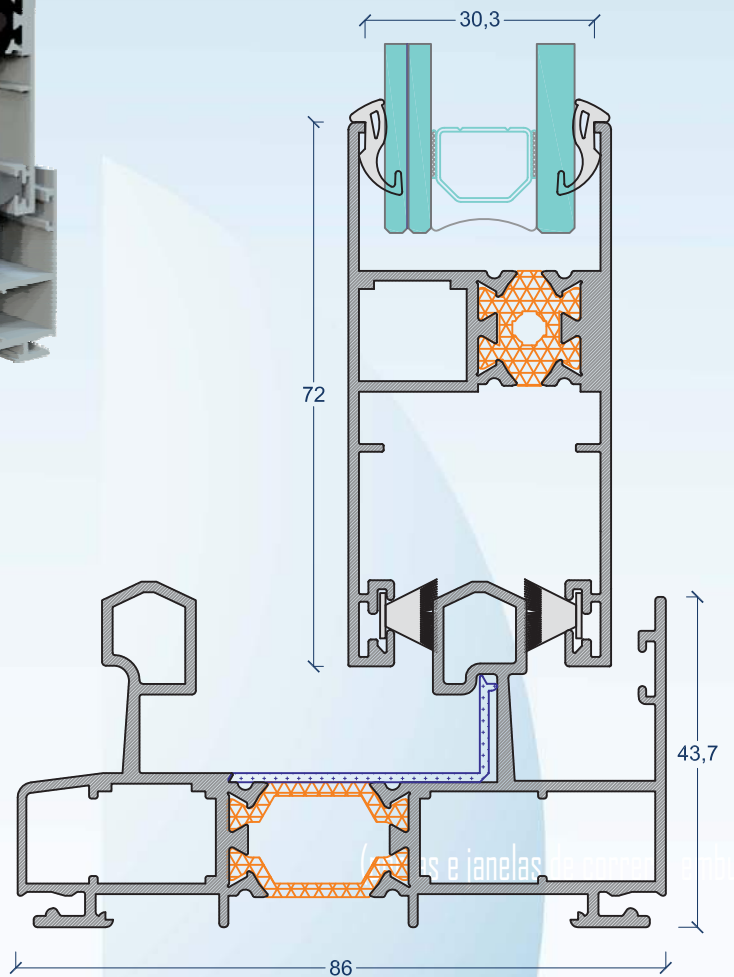

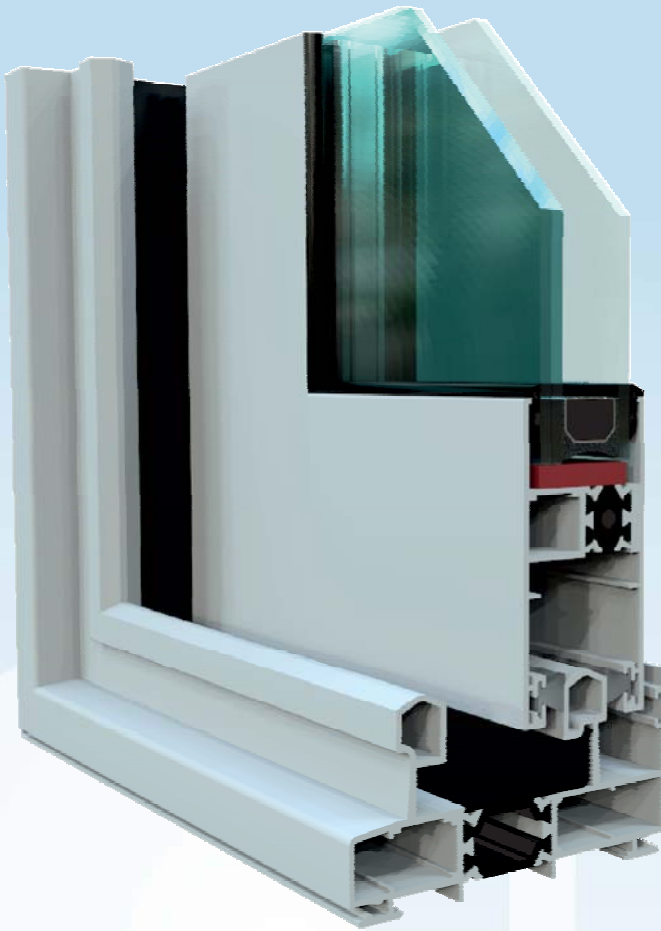

Laboratório Nacional de Engenharia Civil, I.P.
DEPARTAMENTO DE EDIFÍCIOS
Núcleo de Acústica, Iluminação, Componentes e Instalações
LEC - Laboratório de Ensaios de Caixilharia
Organismo Notificado nº0856

Boletim nº 1509- LNEC/LEC
Pág: 12/12
Pedido nº
Director do DED
Visito
I Vascóncelos Paiva
Departamento de DED

4.4.3 - Ensaio de Resistência no Plano da Folha**

Norma de ensaio: EN 14808
Norma de classificação: EN 13115
Período de condicionamento: > 4 horas
Data do ensaio: 2008/06/23
Temperatura: 17,4 °C
Humidade Relativa: 54 %

Ao aplicar-se uma força de 800 N, não se observaram deteriorações nem deformações residuais que impedissem o normal funcionamento da folha.
Resultado satisfatório para a classe 4.

5 - CONCLUSÕES

5.1 - No quadro seguinte apresenta-se uma síntese dos resultados aplicáveis ao protótipo submetido a ensaio.

ENSAIO		CLASSE
Permeabilidade ao ar		3
Estantiquidade à água		7A
Resistência à pressão do vento	Pressão de ensaio Flecha dos perfis	5 C
Manobra do fecho**		2
Durabilidade**		2
Resistência no plano da folha**		4

5.2 - As classificações de permeabilidade ao ar e de estantiquidade à água dependem dos rasgos de drenagem de água e das linhas de vedação existentes no protótipo ensaiado e descritos na secção 2. Qualquer modificação nestes rasgos ou nas linhas de vedação, pode implicar a alteração do desempenho do protótipo.

5.3 - Os resultados do ensaio são apenas válidos para o protótipo ensaiado com os perfis e acessórios especificados na secção 2, devendo ser tidas em conta as regras de extrapolação previstas na norma EN 14351-1 (2006).

5.4 - A durabilidade dos perfis de corte térmico deve ser evidenciada através de resultados satisfatórios nos ensaios previstos na norma EN 14024 (2004).

Lisboa 25 de Maio de 2009

Técnico Experimentador

José A. Martins
Técnico Especialista Principal

Carlos F.K. Saldanha
Auxiliar Técnico de Ensaios

O Chefe do Laboratório de Ensaios

Amando Teófilo Pinto
Investigador Auxiliar

certificado de ensaio



Área Acad. nº 3
20720 ACERTEIRA (Sapizoaia)
Tel: 343 813500 - Fax: 343 813044
Email: cidemco@cidemco.es
http://www.cidemco.es

ORGANISMO NOTIFICADO
nº 1239

EMPRESA LINGOTE - ALUMINIOS, LDA
ENDEREÇO ZONA INDUSTRIAL DO SOCORRO, LOTE B2
4820-000 FAFE (PORTUGAL)
Nº CERTIFICADO 22489/22605-e

Descrição do produto e modelo	JANELA ALUMINIO DE CORRER DUAS FOLHAS «LIN 203000RT»
Dimensões	(1.500 x 1.200) mm

DETERMINAÇÃO DA ATENUAÇÃO ACÚSTICA (ANEXO B, UNE-EN 14351-1:2006)	$R_{d(C; C_{10})} = 27 (-1; -2)$ dB
Determinação da atenuação acústica	

DETERMINAÇÃO DE TRANSMISSÃO TÉRMICA «U» (UNE-EN ISO 12567-1:2002)	$U = 4,1$ W/m ² K
Coefficiente de transmissão térmica «U _{e,s} »	

FECHA 30 de Junho 2009

Este documento não tem validade sem o relatório de testes nos quais os resultados são indicados obtido em cada teste.
Os resultados obtidos nestes testes são referidos a (S) isto especificando analisaram (S) neste Centro na data caracterizada e eles não incluem um caracterizada de preservação na qualidade do produto.

Foto: Miguel Marques
Resp: Área Fachadas Ligetas

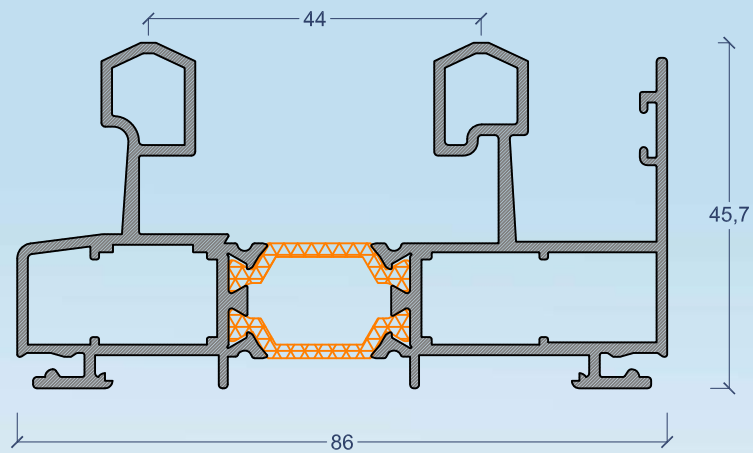

LEM.01

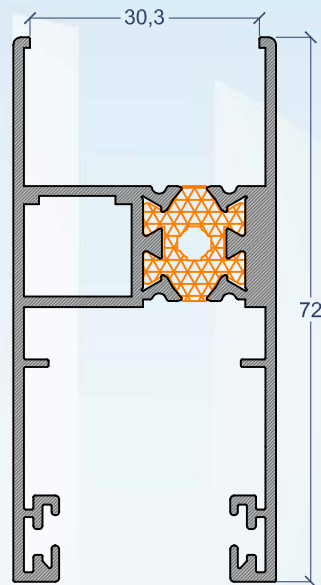

LEM.02

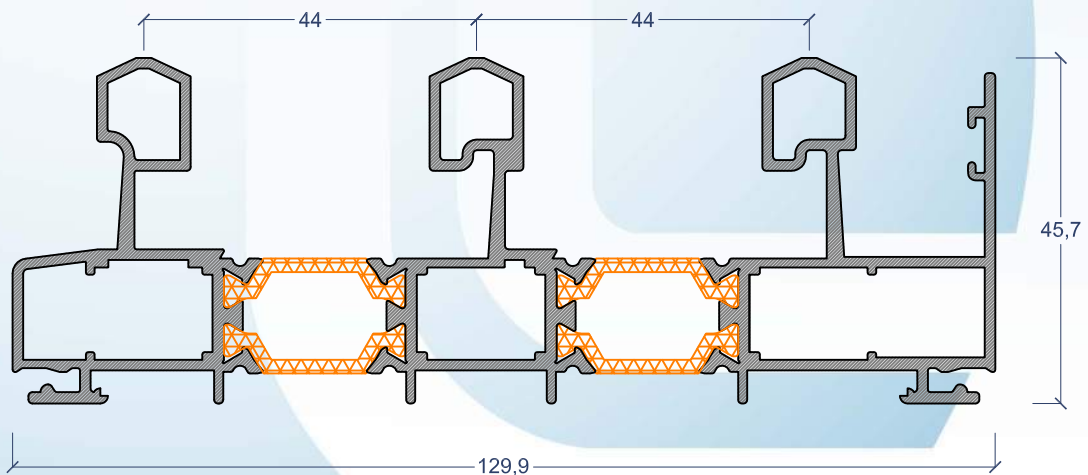

LEM.51

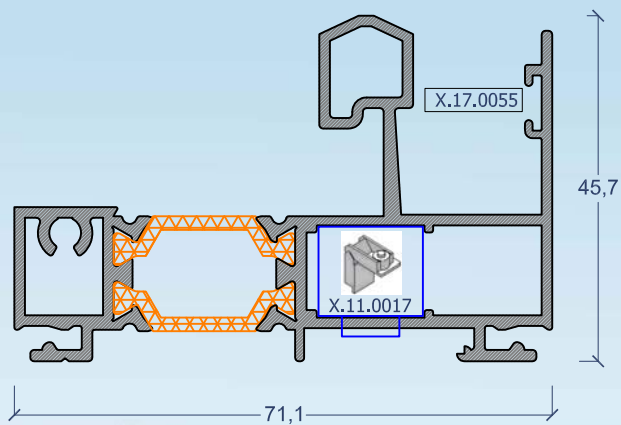

LEM.21

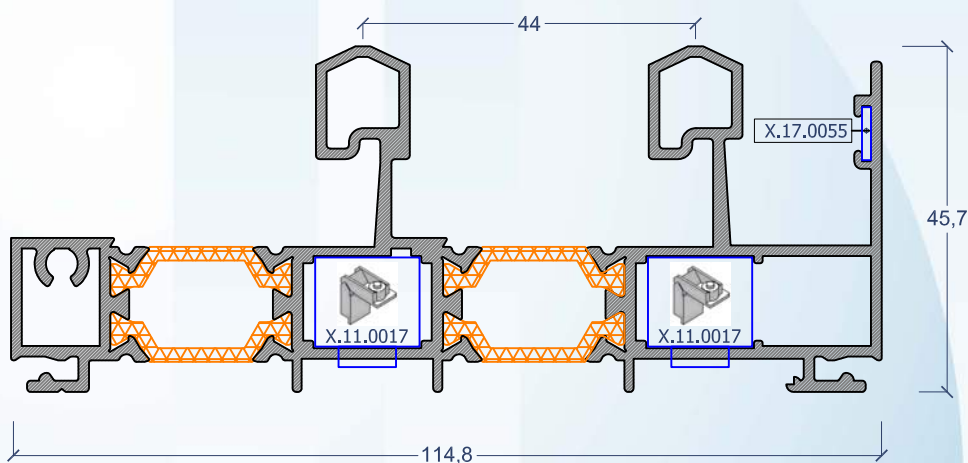

LEM.31

Tipo A	Tipo B	Tipo C	Tipo D	Tipo E	Tipo F
mono rãll 1 folha	mono rãll 1 folha com portada	correr 2 folhas	correr 2 folhas mono rãll	correr 2 folhas com portada	correr 4 folhas



LEM.04

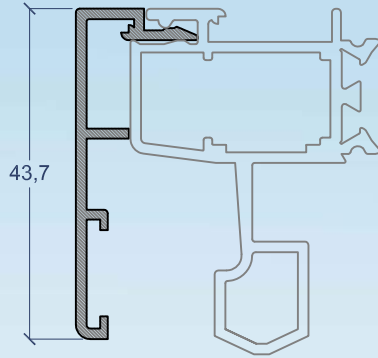

LEM.08

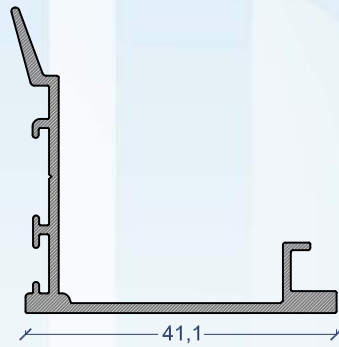
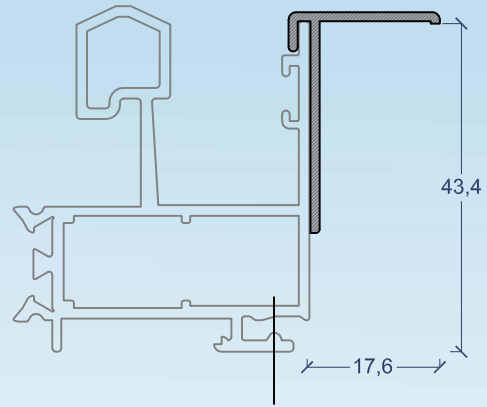

LEM.03

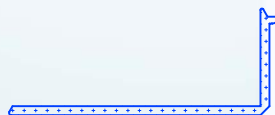

LEM.05
Capa aro fixo PVC



LEM.06
Inversor Folha PVC

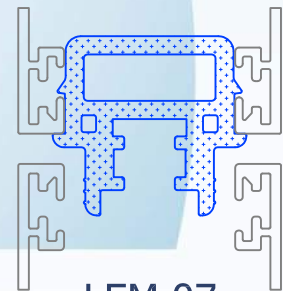

LEM.07
Central 4 Fls PVC

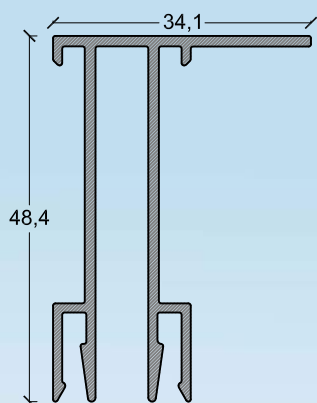

LEM.13

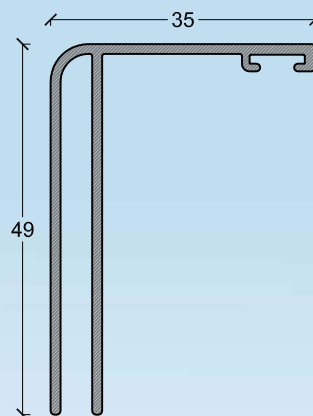

LEM.14

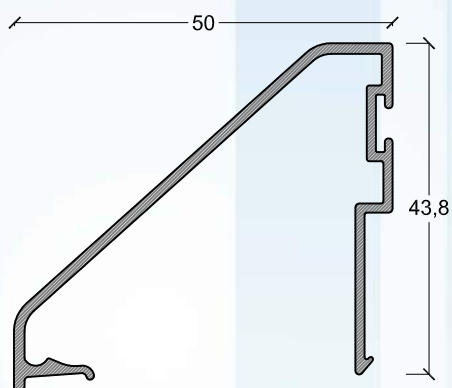

LEM.15

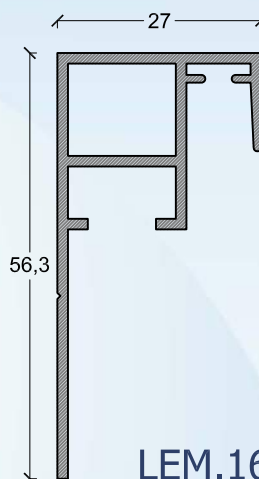

LEM.16

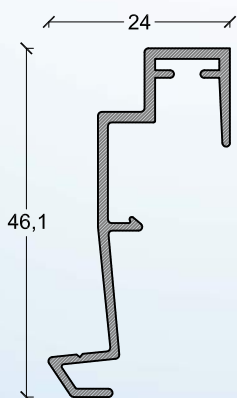

LEM.17

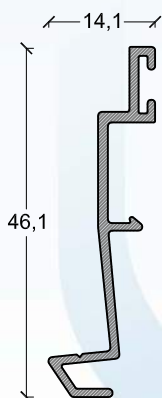

LEM.18

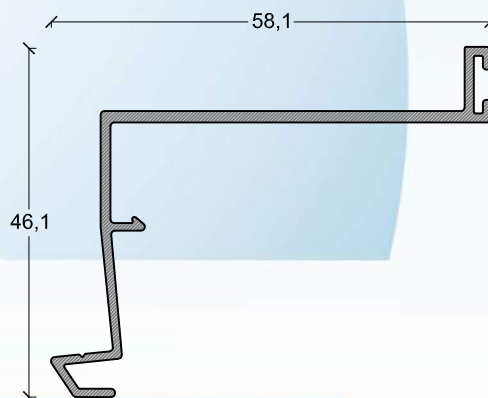

LEM.19

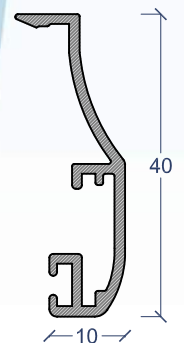
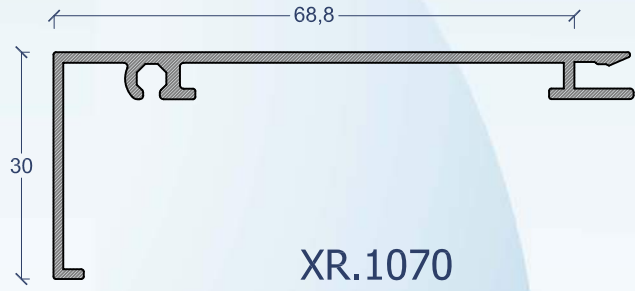
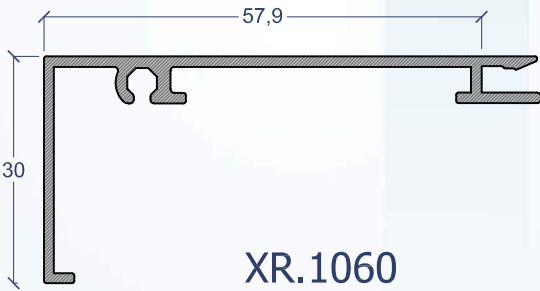
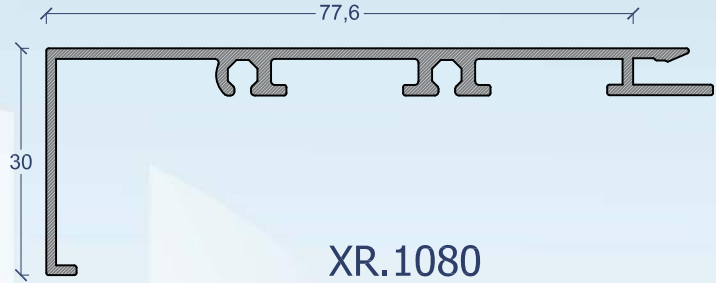
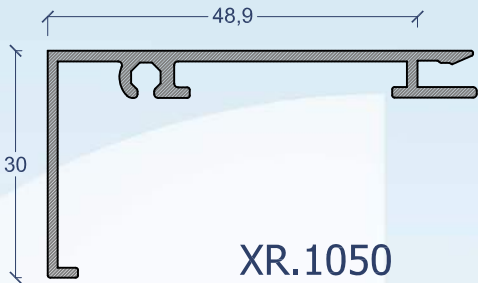
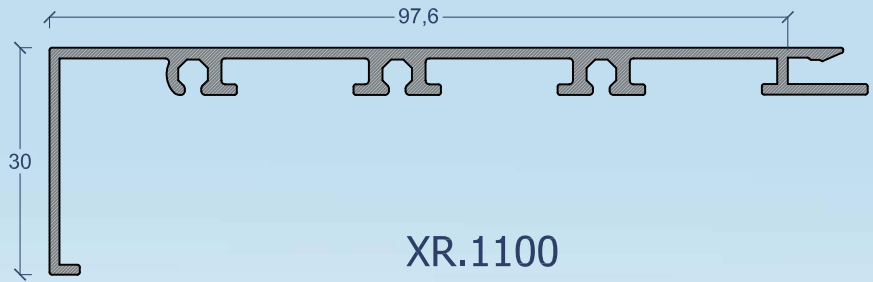
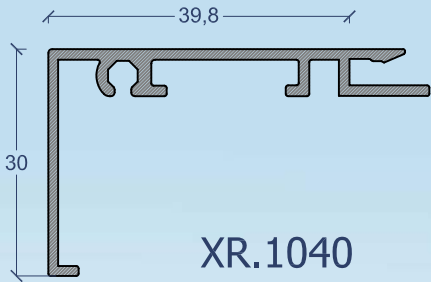



Le Mans

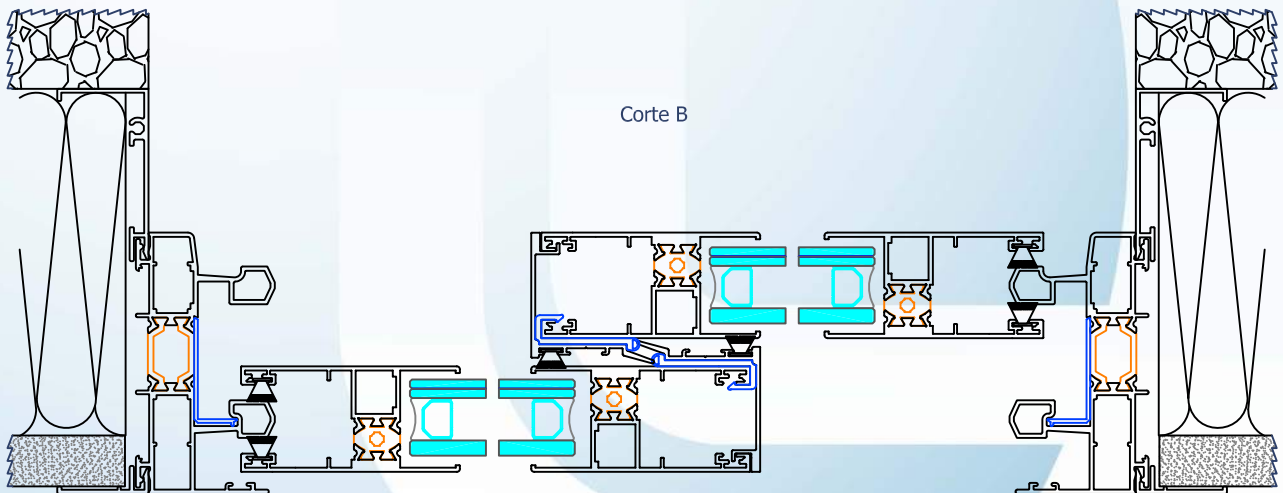
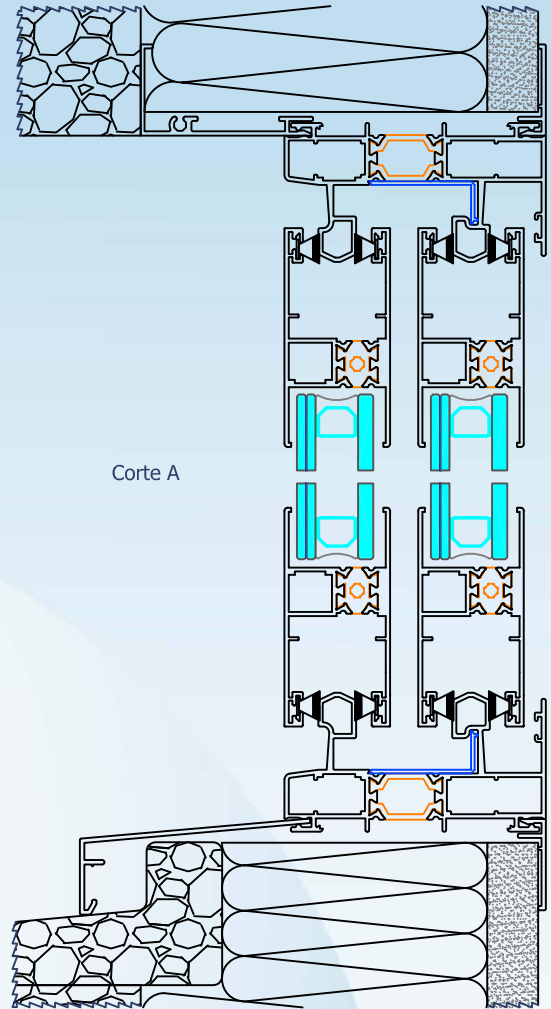
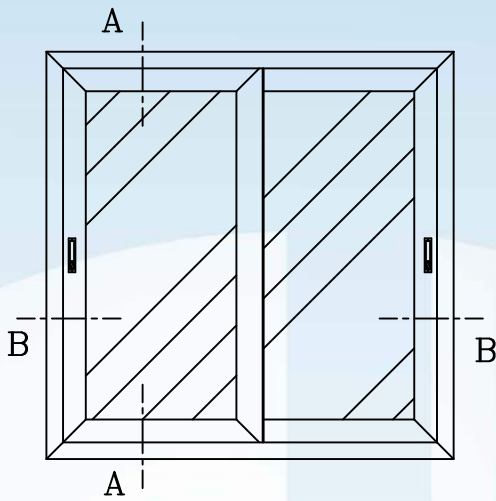



Le Mans

Galandage 1 folha

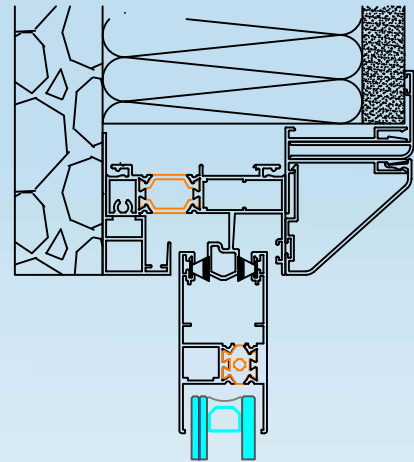
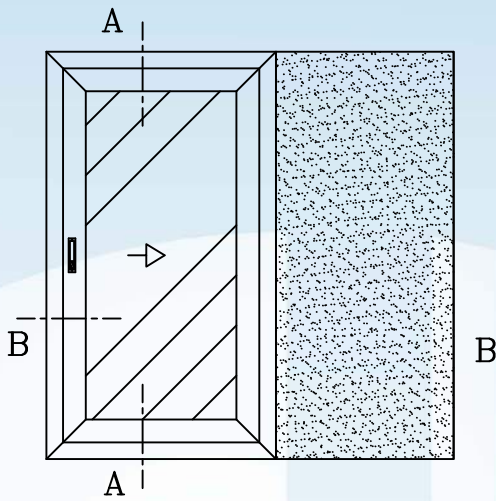

Corte A

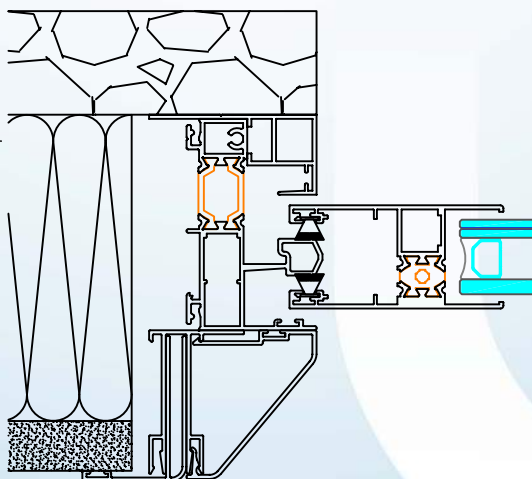
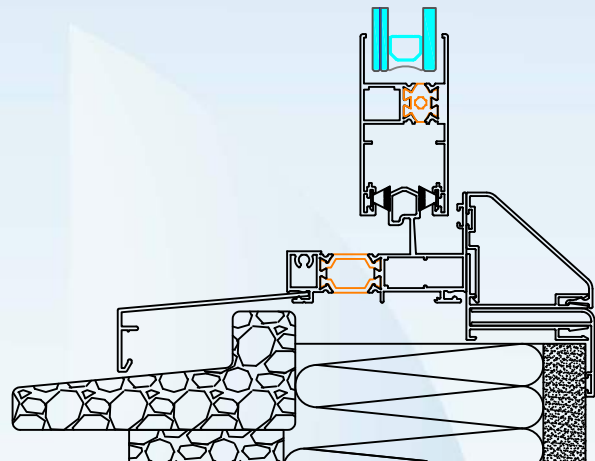

Corte B

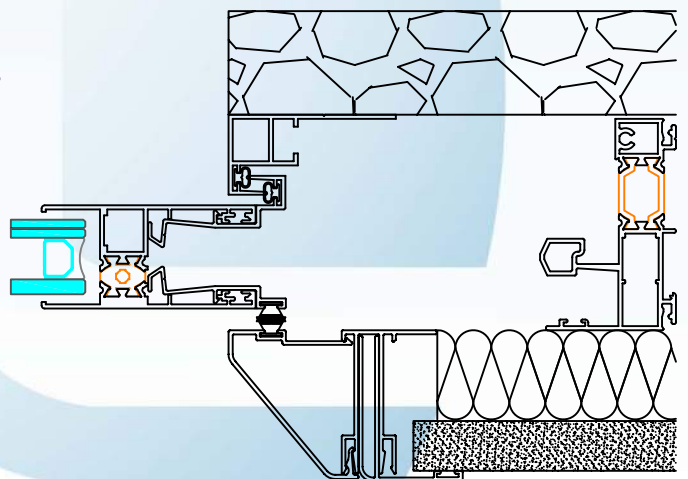



Le Mans

Galandage 1 folha com monobloco

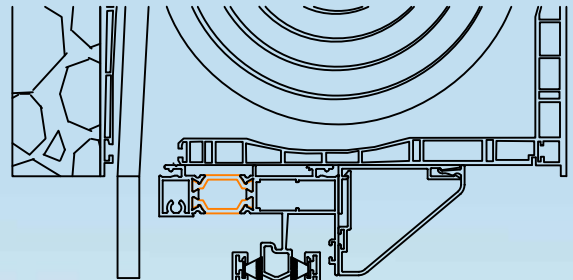
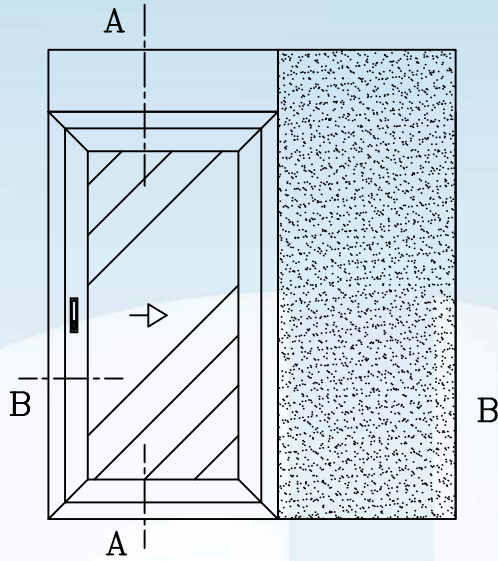

Corte A

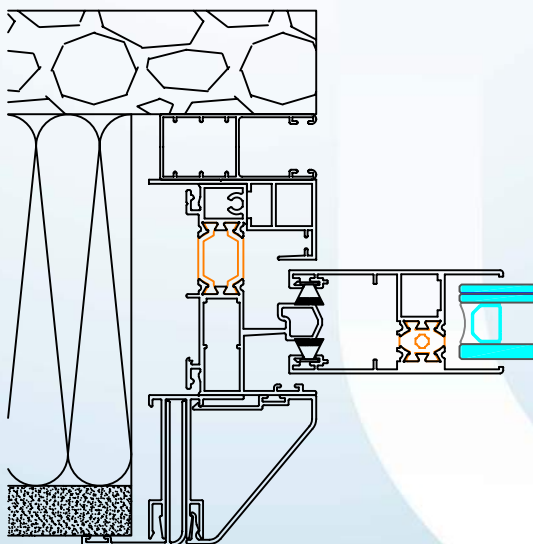
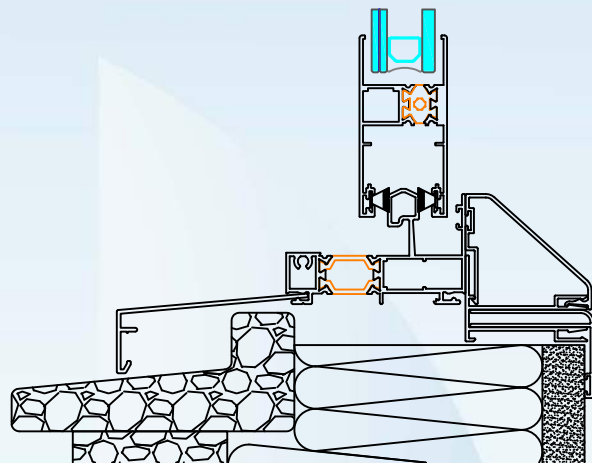

Corte B

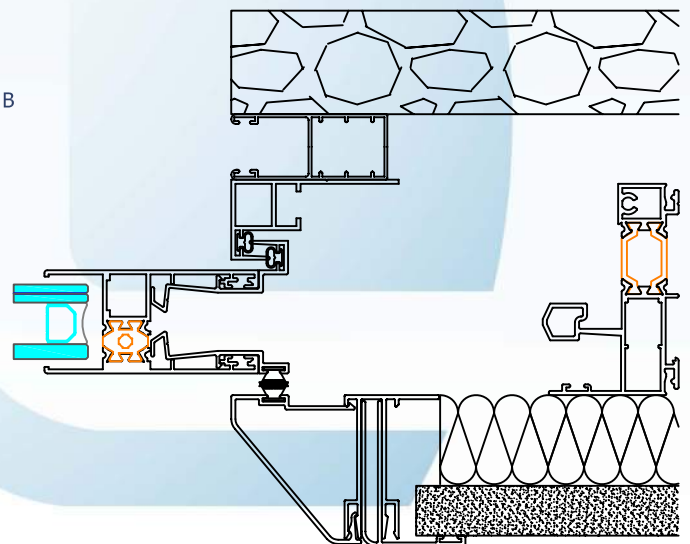



Le Mans

Galandage 1 folha com portada

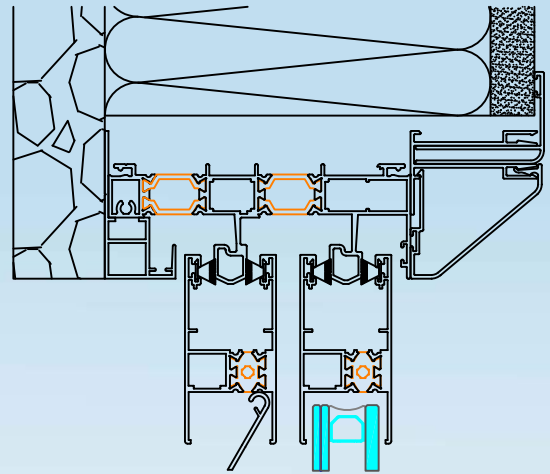
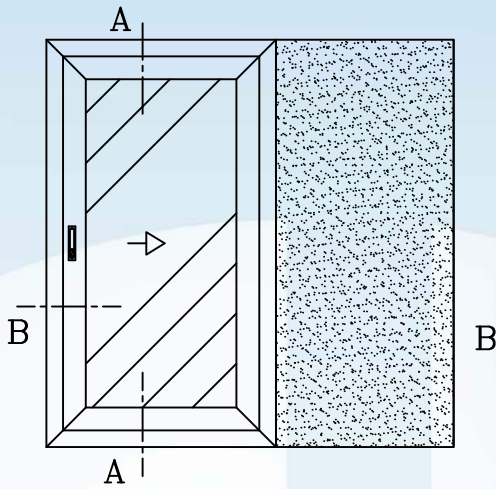

Corte A

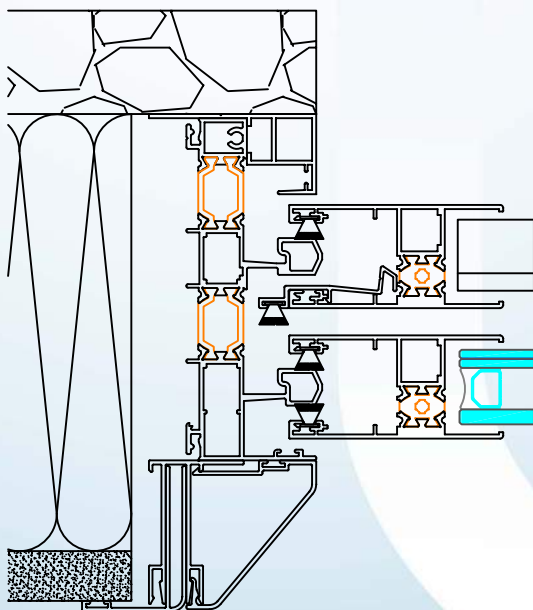
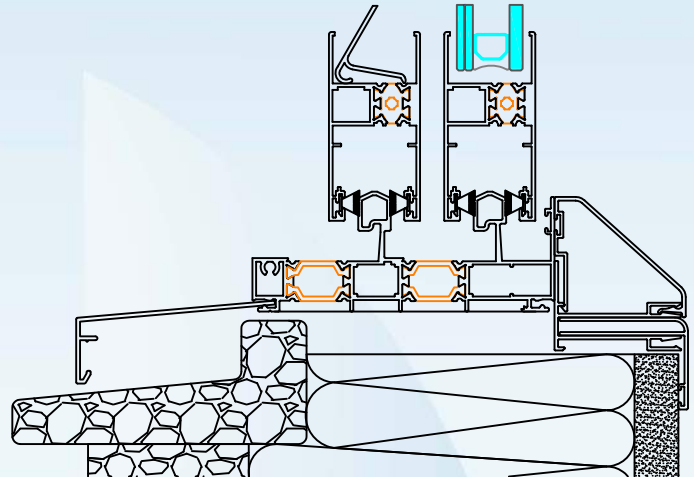

Corte B

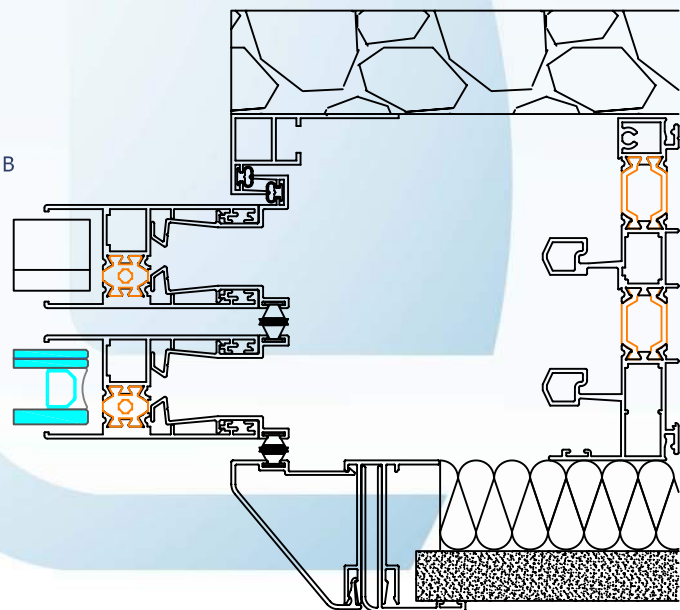



Le Mans

Galandage 2 folhas monorail

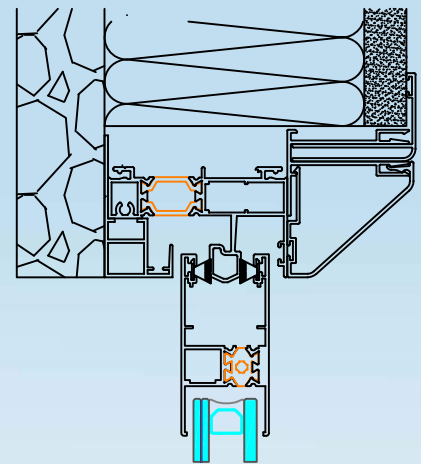
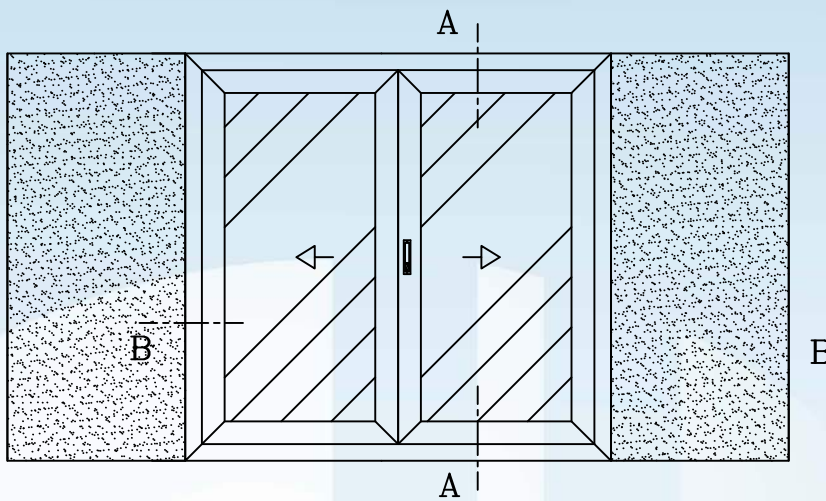

Corte A

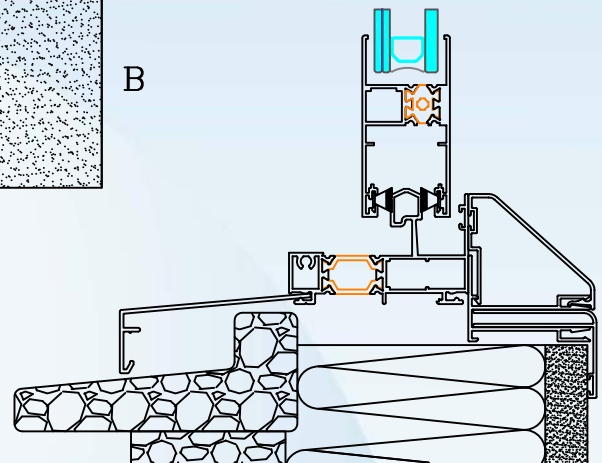

Corte B

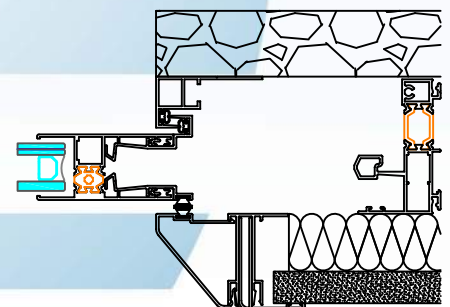
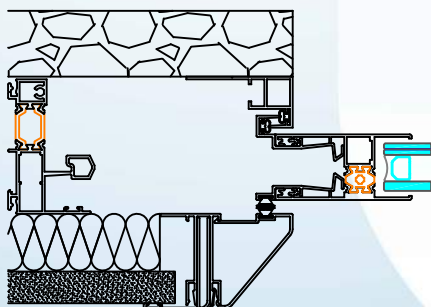



Le Mans

Galandage 2 folhas birail

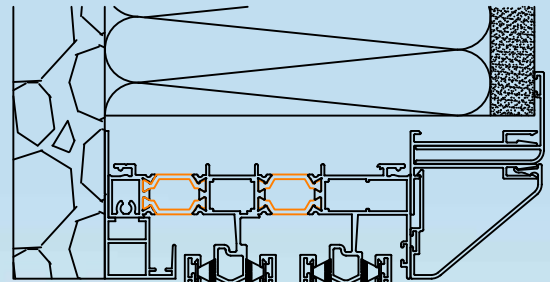
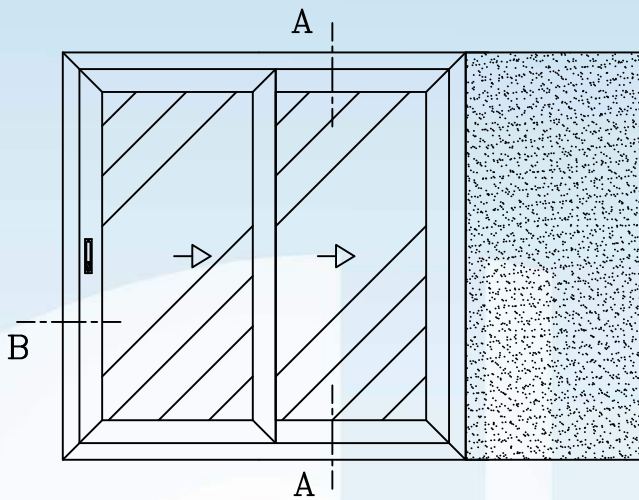

Corte A

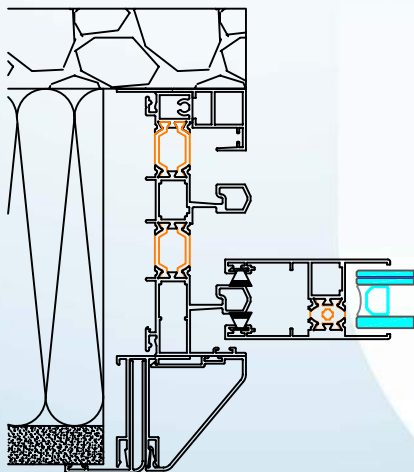
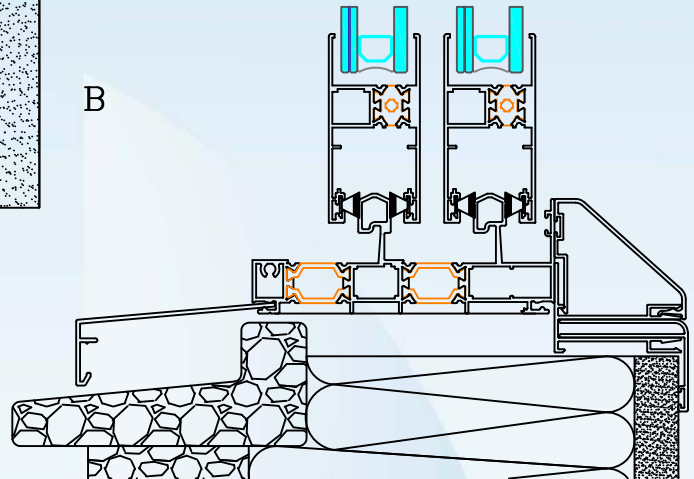

Corte B

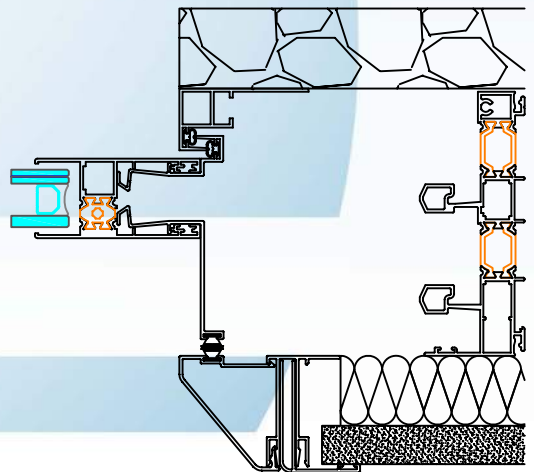
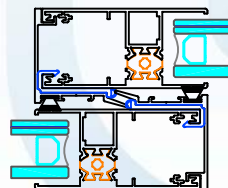



Le Mans

Outras possibilidades construtivas

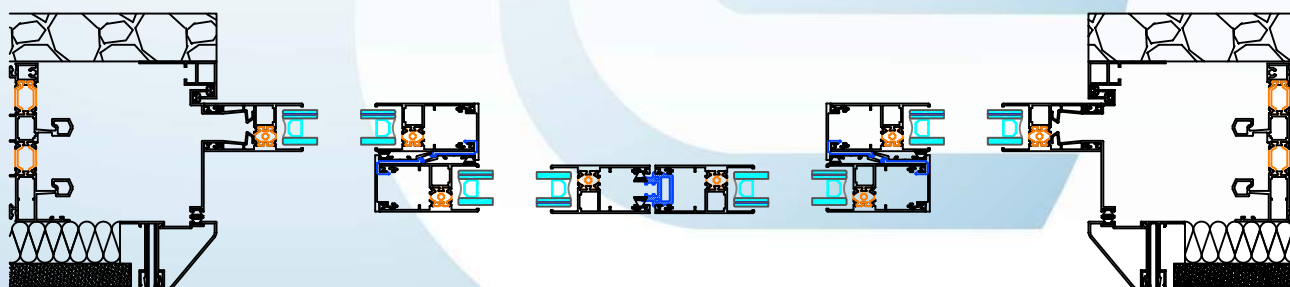
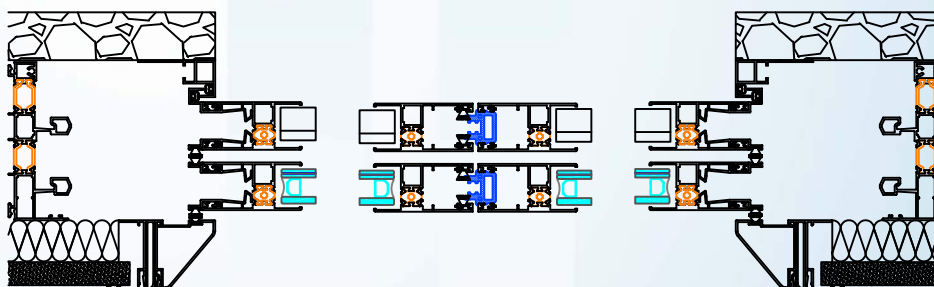
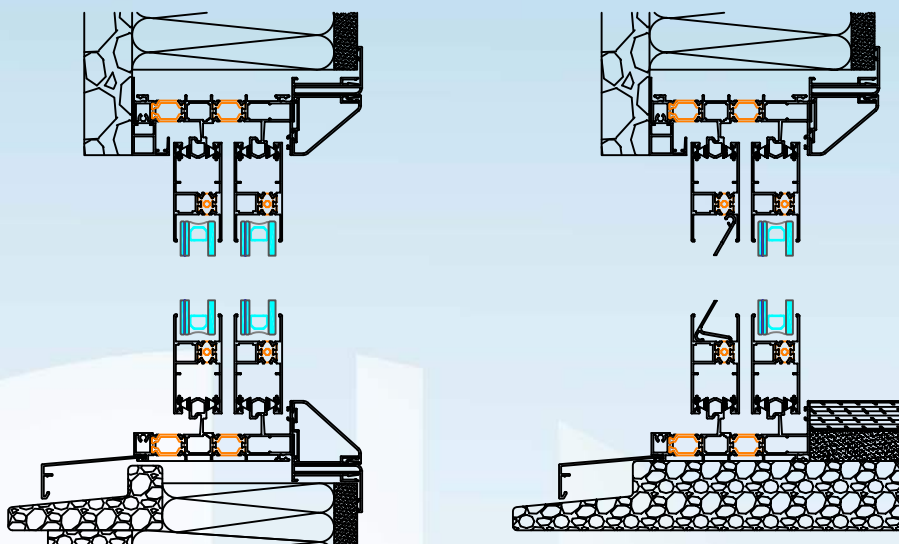



Medidas de corte

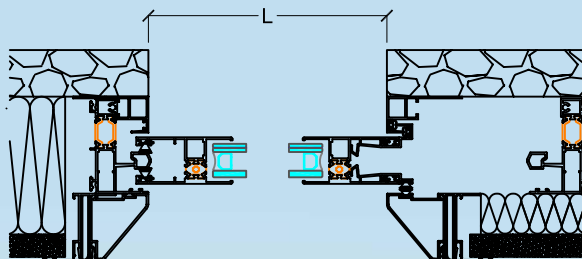

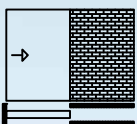
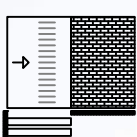
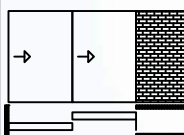
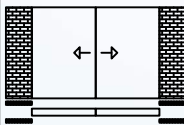
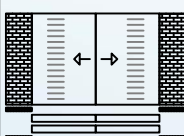
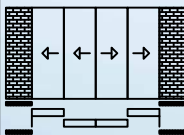
		Largura	Altura
Tipo A mono rail 1 folha 	Fixo	$L + 18 \times 2$	$A + 43,7$
	Móvel	$L + 18$	$A - 25,5$
Tipo B mono rail 1 folha com portada 	Fixo	$L + 18 \times 2$	$A + 43,7$
	Móvel	$L + 18$	$A - 25,5$
Tipo C correr 2 folhas 	Fixo	$L + 87 / 2 \times 3 - 66$	$A + 43,7$
	Móvel	$L + 87 / 2$	$A - 25,5$
Tipo D correr 2 folhas mono rail 	Fixo	$L + 14 \times 2 - 65$	$A + 43,7$
	Móvel	$L + 14 / 2$	$A - 25,5$
Tipo E correr 2 folhas com portada 	Fixo	$L + 14 \times 2 - 65$	$A + 43,7$
	Móvel	$L + 14 / 2$	$A - 25,5$
Tipo F correr 4 folhas 	Fixo	$L + 152 / 4 \times 6 - 196$	$A + 43,7$
	Móvel	$L + 152 / 4$	$A - 25,5$

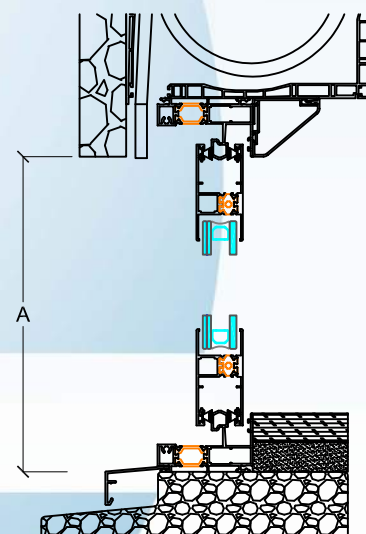
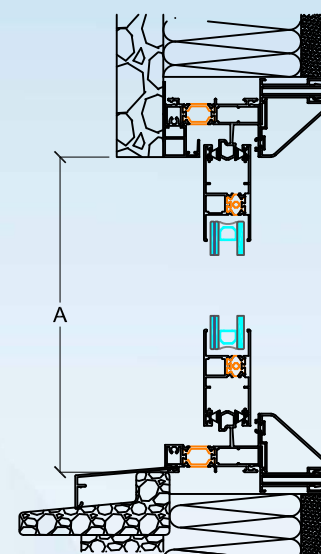



Acessórios

Le Mans



X.11.0017

Esq. M37 (14x12) MC-460.8

unid.



X.17.0027

Esq. alinh.(1.2x14.2) CCT-16 Picado

unid.

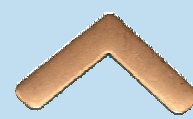

X.17.0029

Esq. alinh.(1.0x6,6) CCT-23

unid.



X.28.0061

Rolam. 150kg Le Mans 9530.1 CT

unid.



X.52.0104

Guia Batente Le Mans SK9709PI

unid.



X.52.0105

Guia Central Le Mans I487P

unid.



X.31.0029

Fecho lateral 257 i

unid.



X.33.0042

Engate Gancho 36

unid.



X.33.0040

Ponto de fecho engate 28

unid.



X.30.0085

Cremone multiponto normal

unid.

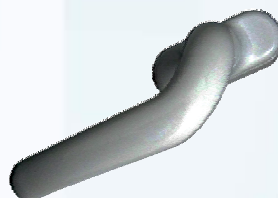

X.30.0098

Cremone multip. descent. esquerda

unid.



X.30.0097

Cremone multip. descent. direito

unid.

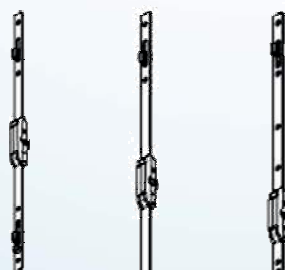

X.31.0072
(60 cm)
(2 pontos Fecho)

X.31.0073
(100 cm)
(2 pontos Fecho)

X.31.0074
(160 cm)
(3 pontos Fecho)

Fecho multiponto 7,5mm

unid.

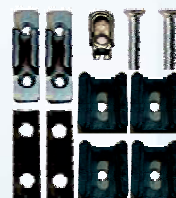

X.35.0028

Kit Calços e p. fecho multip. 2 pontos

kit



X.30.0086

Cremone multiponto de unha

unid.

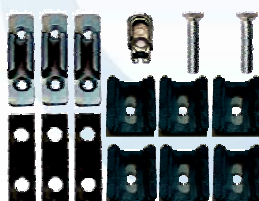

X.35.0029

Kit Calços e p. fecho multip. 3 pontos

kit



X.31.0076

Face externa multiponto

unid.



Acessórios

Le Mans



X.47.0023

Peça Ved. Corta Ventos

unid.



X.59.0023

Batente stop slide alum.

unid.



X.59.0076

Batente stop slide zamak

unid.

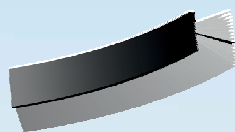

X.40.0012

Pelucia 7x8,5 Stop Fine

mts^(a)



X.43.0022

Ved. A. Movel 2 durezas

mts^(a)



LOUSALU
Alumínios de Lousada, Lda

